

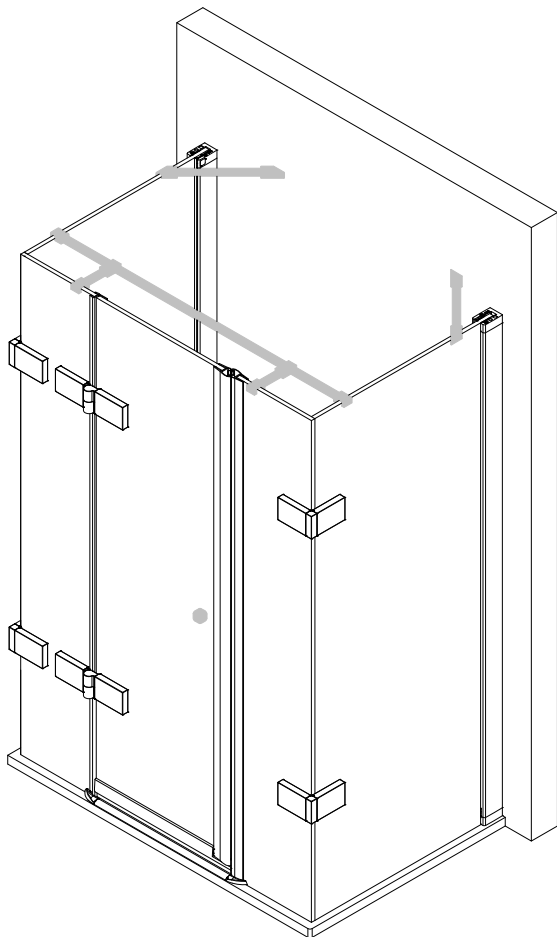

Montageanleitung Installation instructions Instructions de montage Montagehandleiding

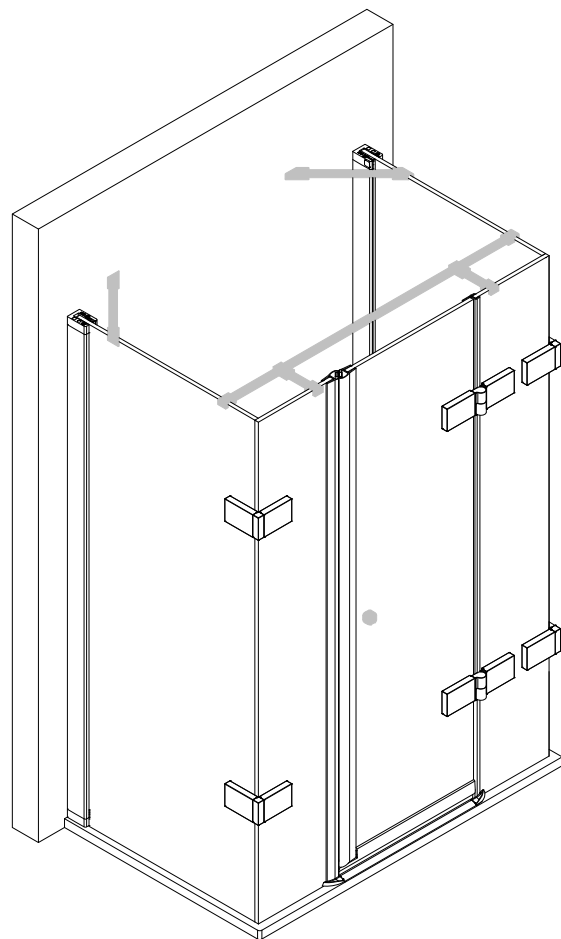

DT an NT + SNT + 2 SW



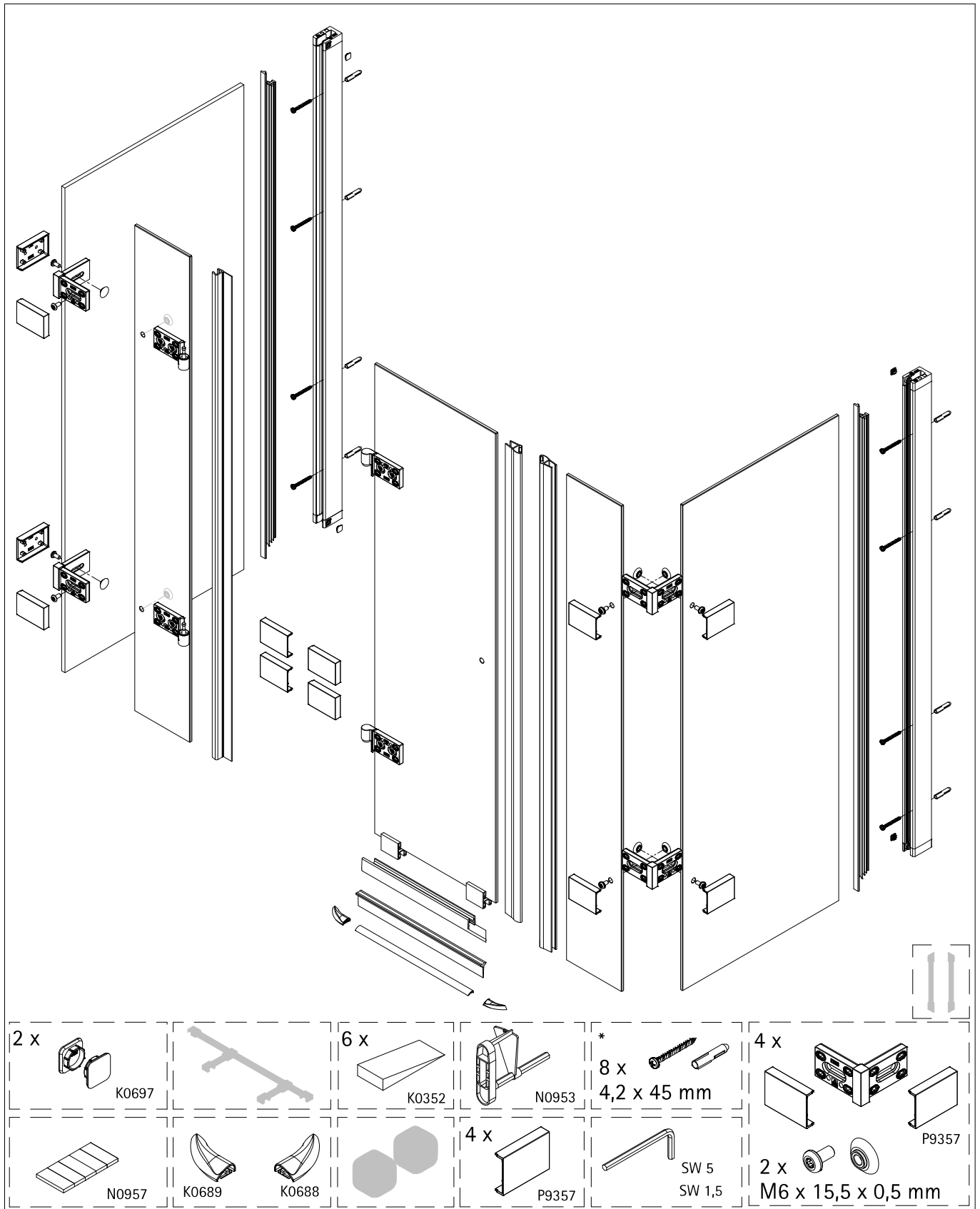

D Dieser universelle Schraubenbeutel wird für verschiedene Arten von Duschtabtrennungen eingesetzt. Die eventuell überzähligen Teile sind deshalb nicht Fehler Ihres Montagevorganges. Wir bitten um Ihr Verständnis.

GB This is a universal set of screws, which is used for various models of our showercubicles. It can occur that you will have more parts in this packet than you need for the assembly of your model. Consequently, if you have parts left, it does not mean that you have made a mistake during assembly. We thank you for your understanding.

F Le sachet de visserie universel est composé pour différents types de pare-douches. Les éventuelles pièces restantes ne proviennent donc pas d'une erreur de montage de votre part. Nous comptons sur votre compréhension.

NL Dit universele schroevenpakket wordt voor diverse types douchecabines gebruikt. Eventueel overtollige onderdelen, betekent niet dat er een fout zou zijn gemaakt bij de assemblage. Wij vragen hiervoor uw begrip.

Ø 6 mm

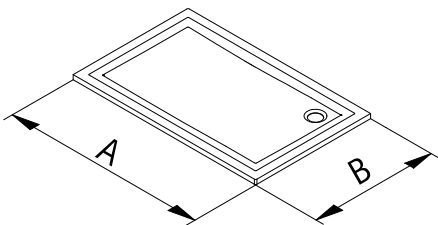
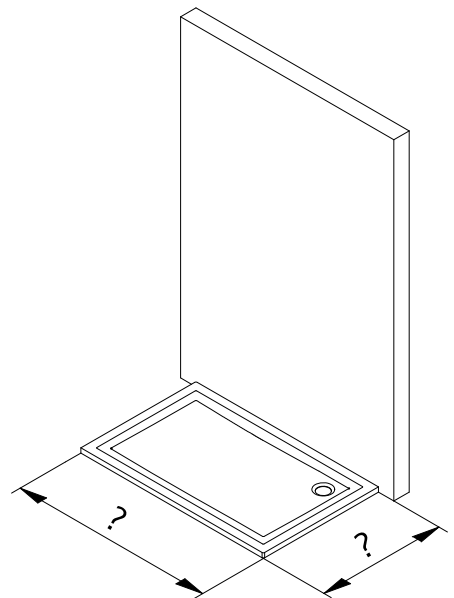
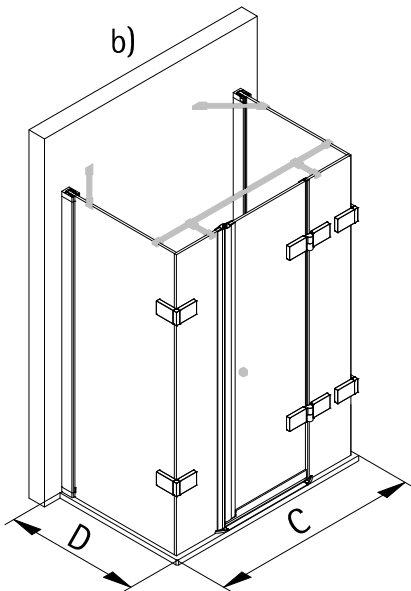
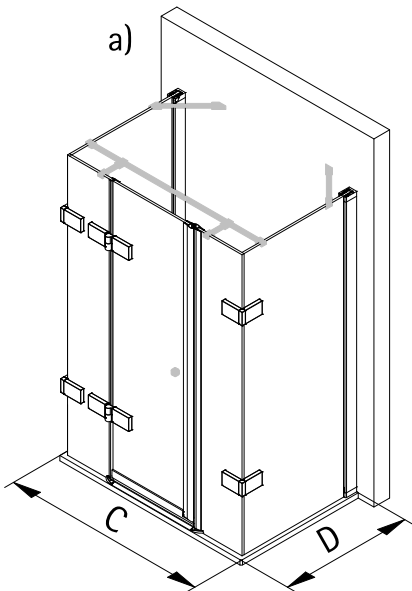
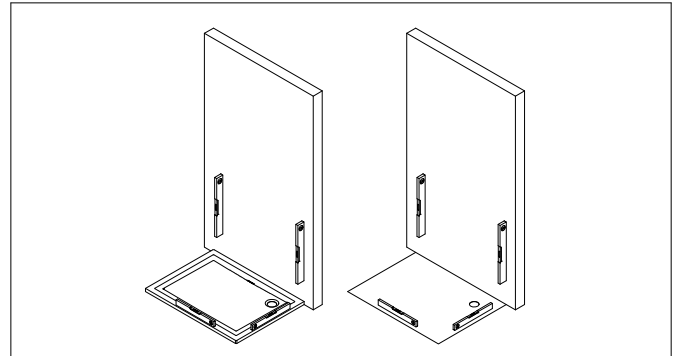
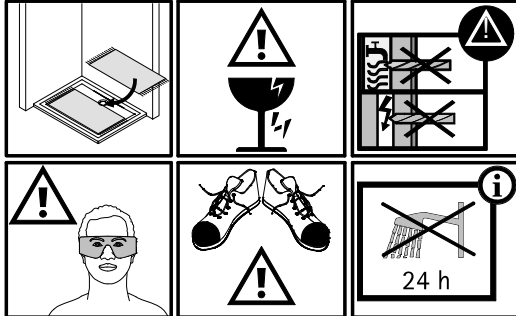
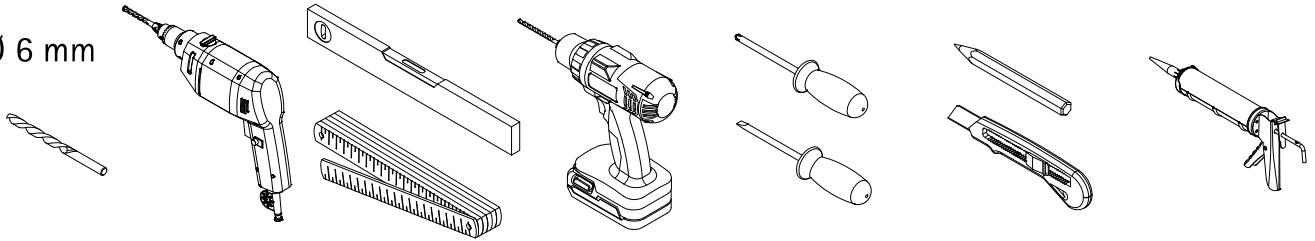

| A | B | C | D |
|---------|--------|---------|--------------|
| 1200 mm | 800 mm | 1168 mm | 790 - 810 mm |

1

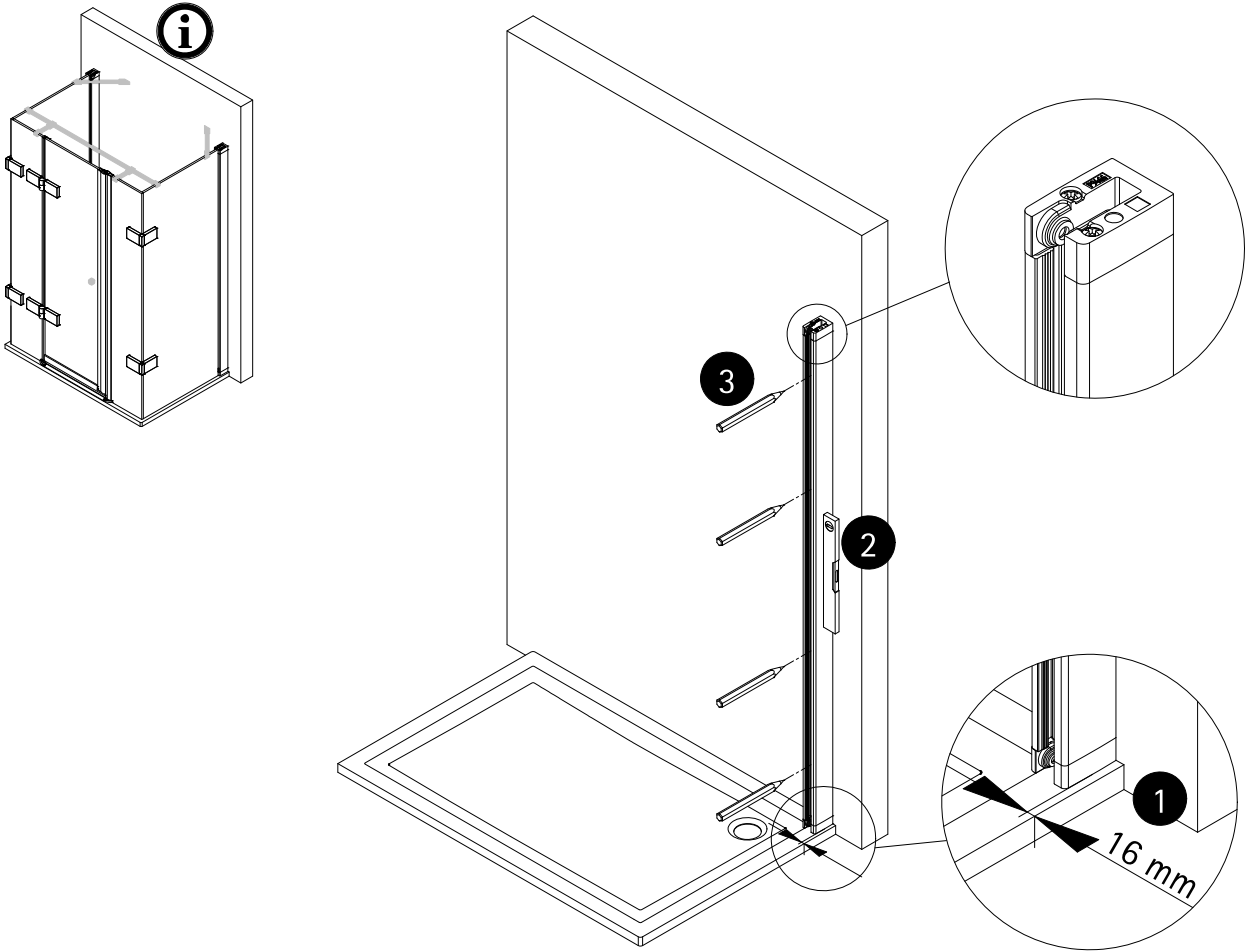

2

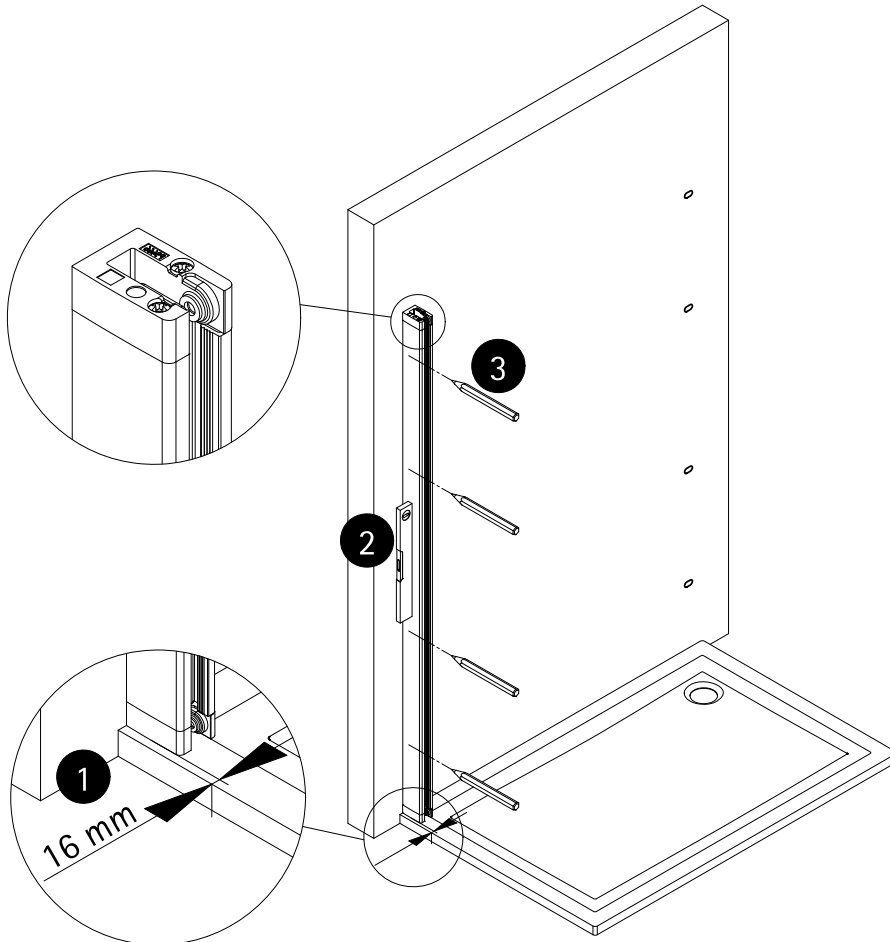

3

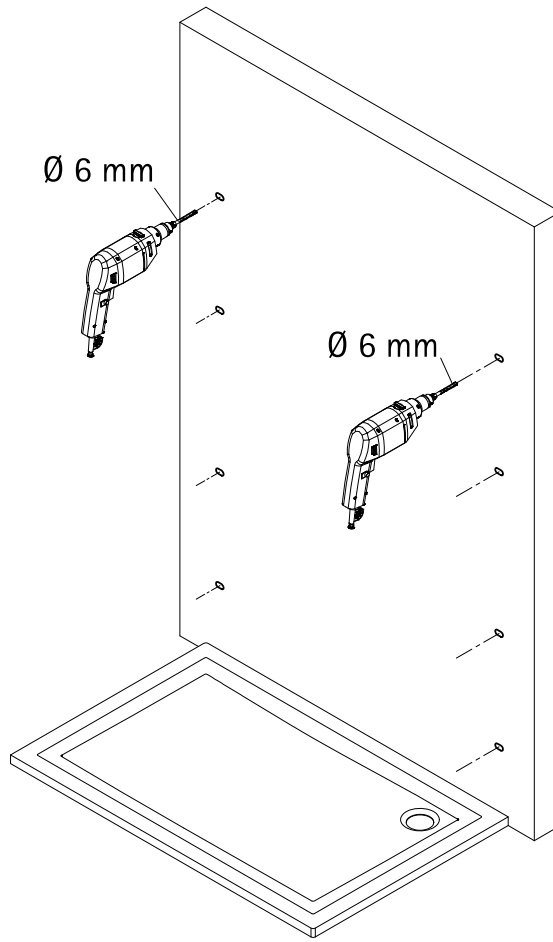
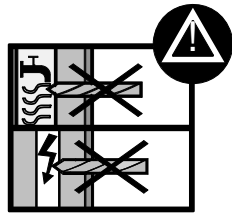

4

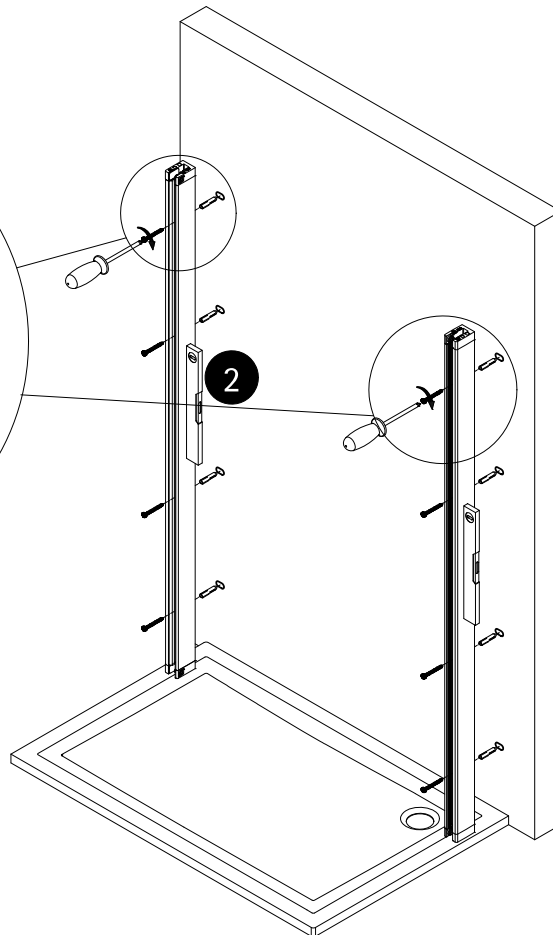
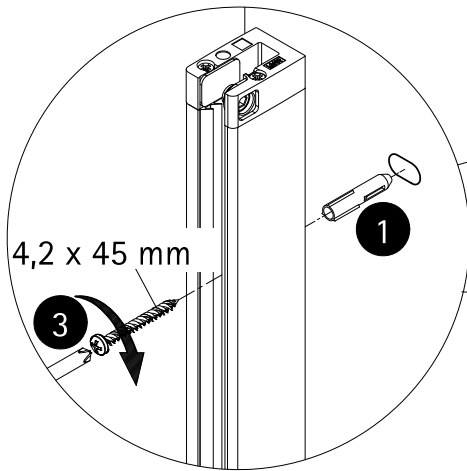

5

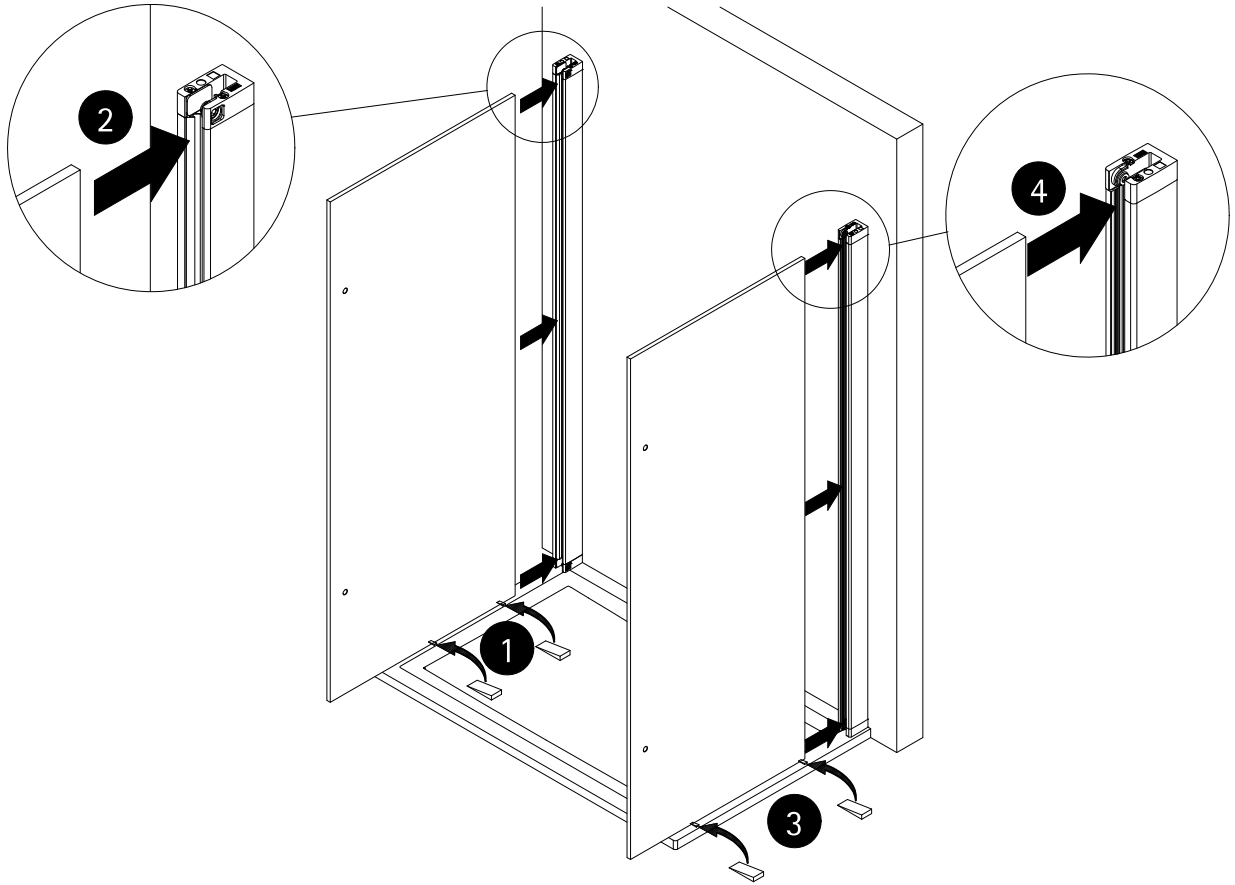

6

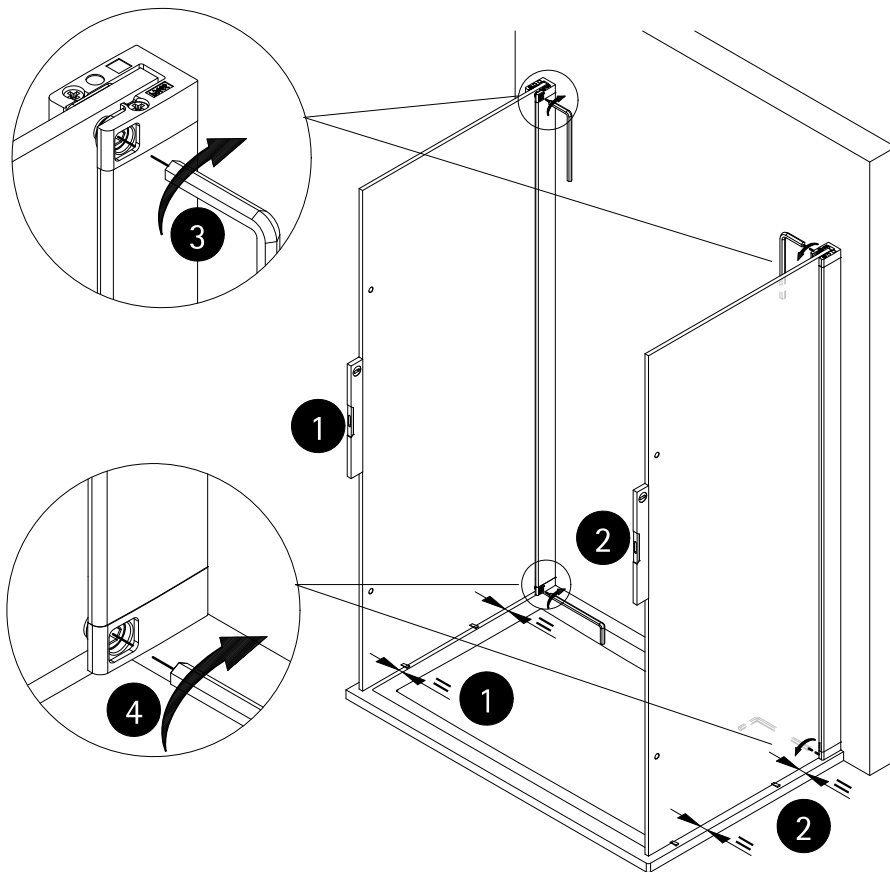

9

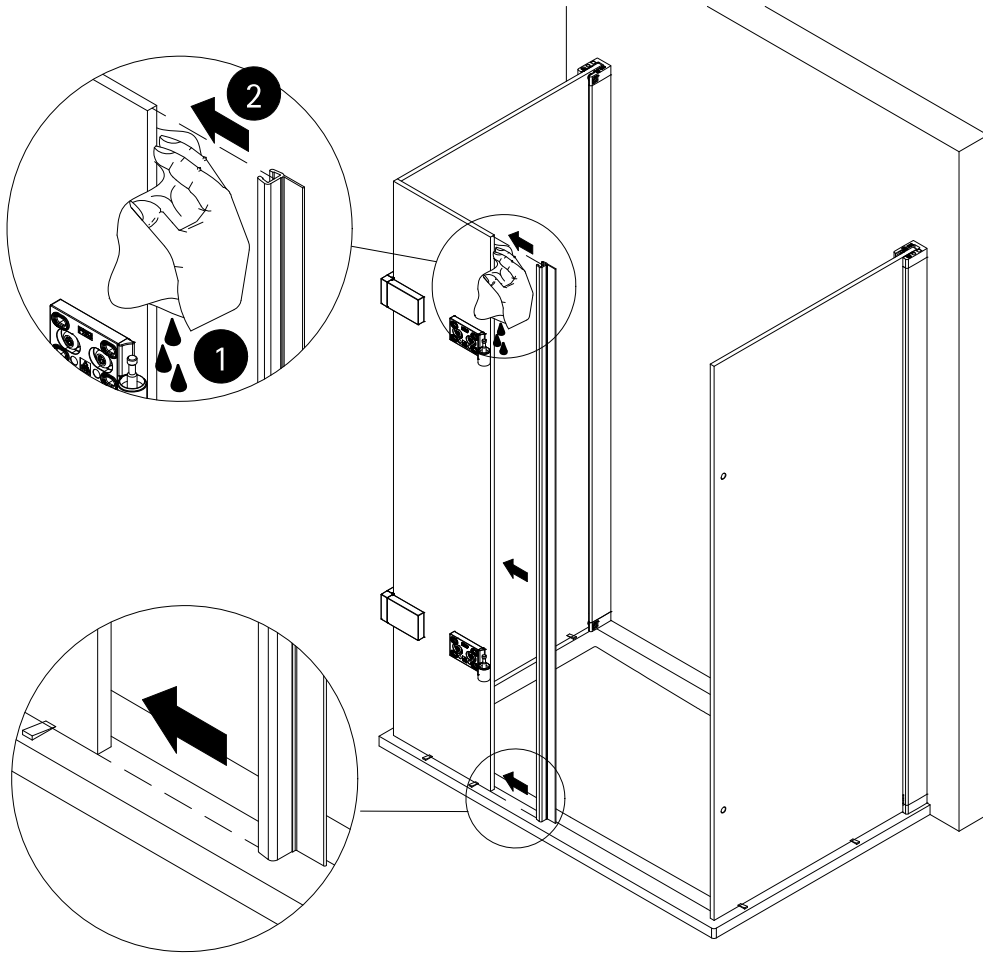

10

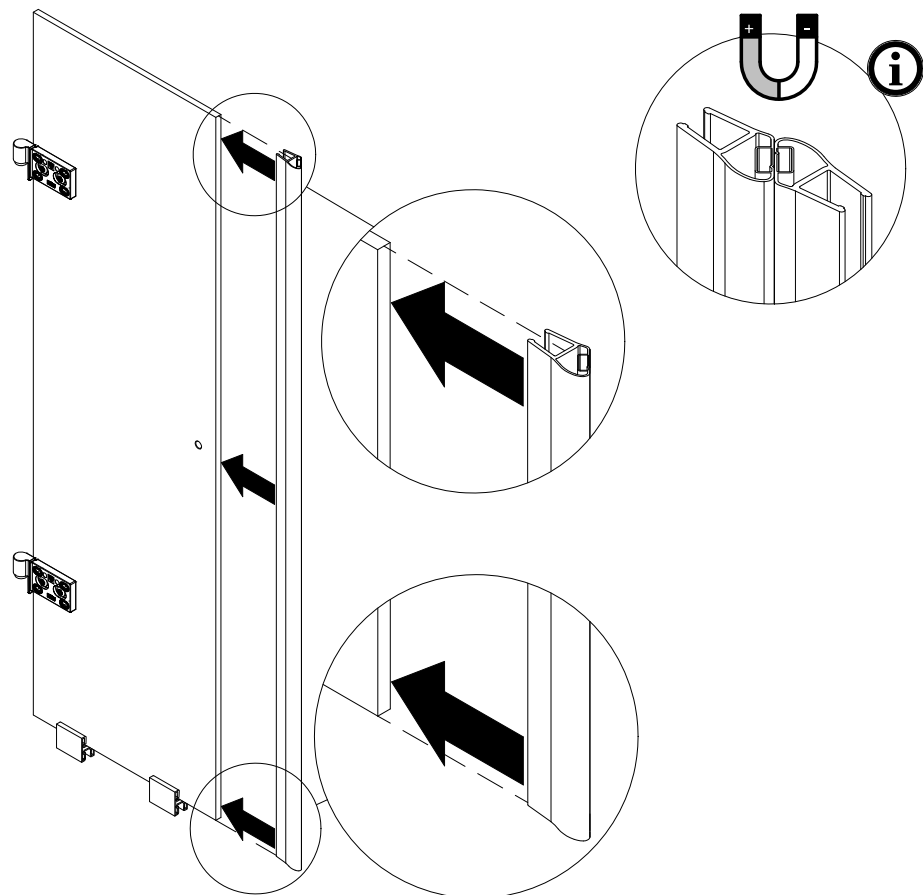

11

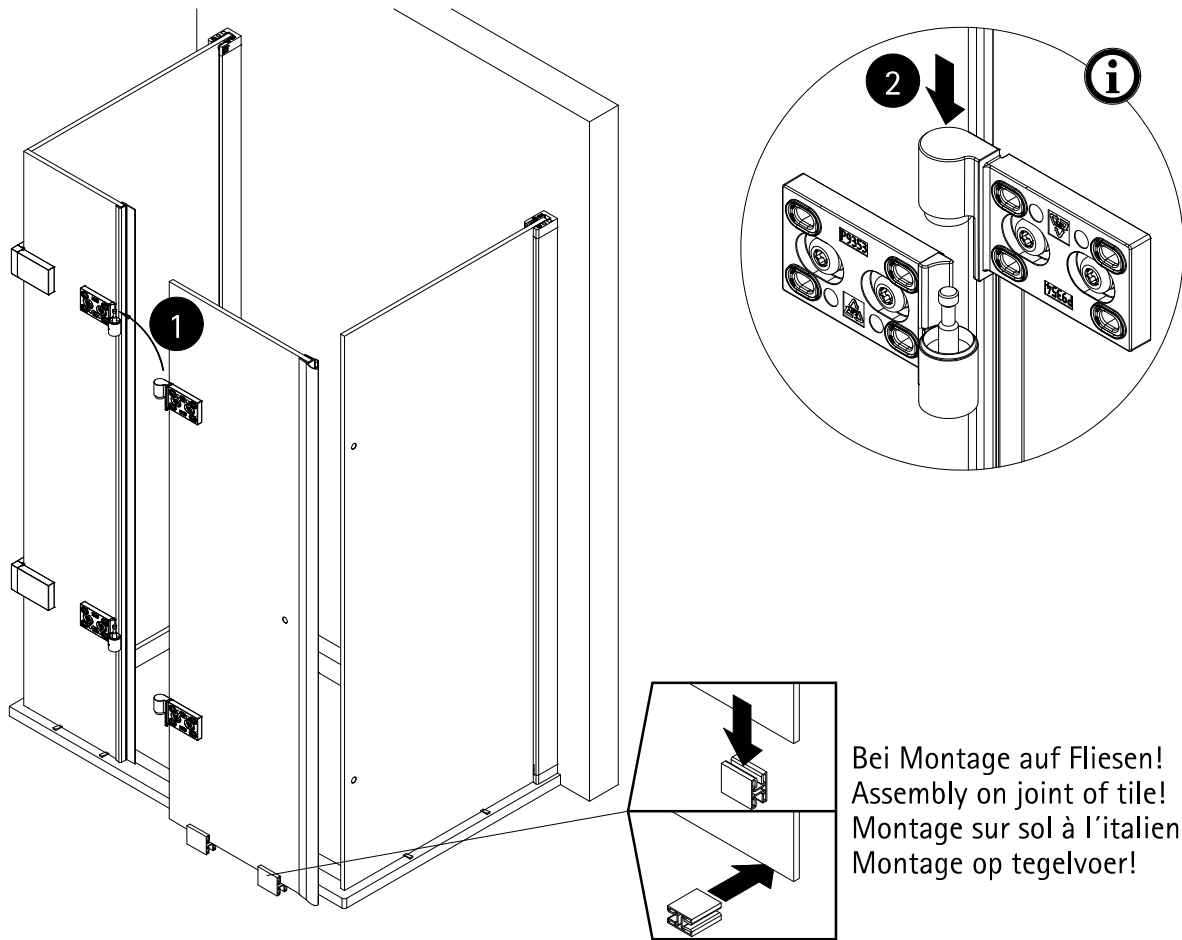

12

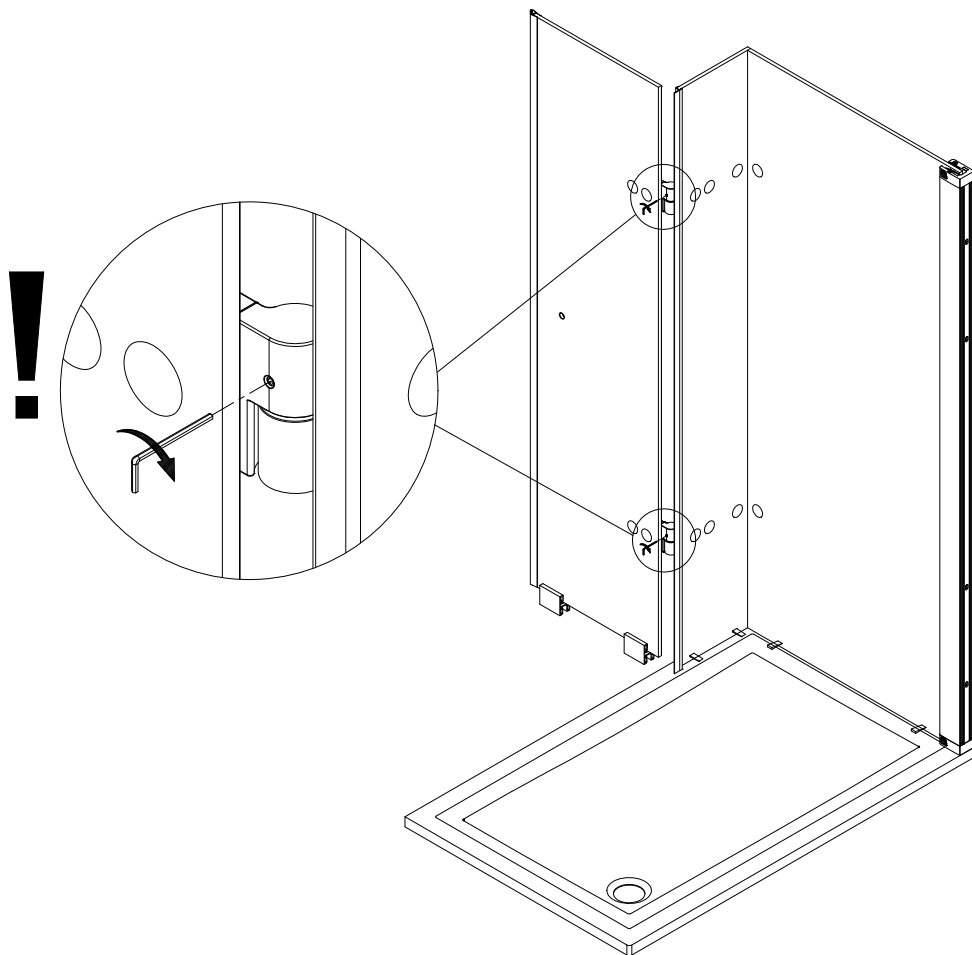

13

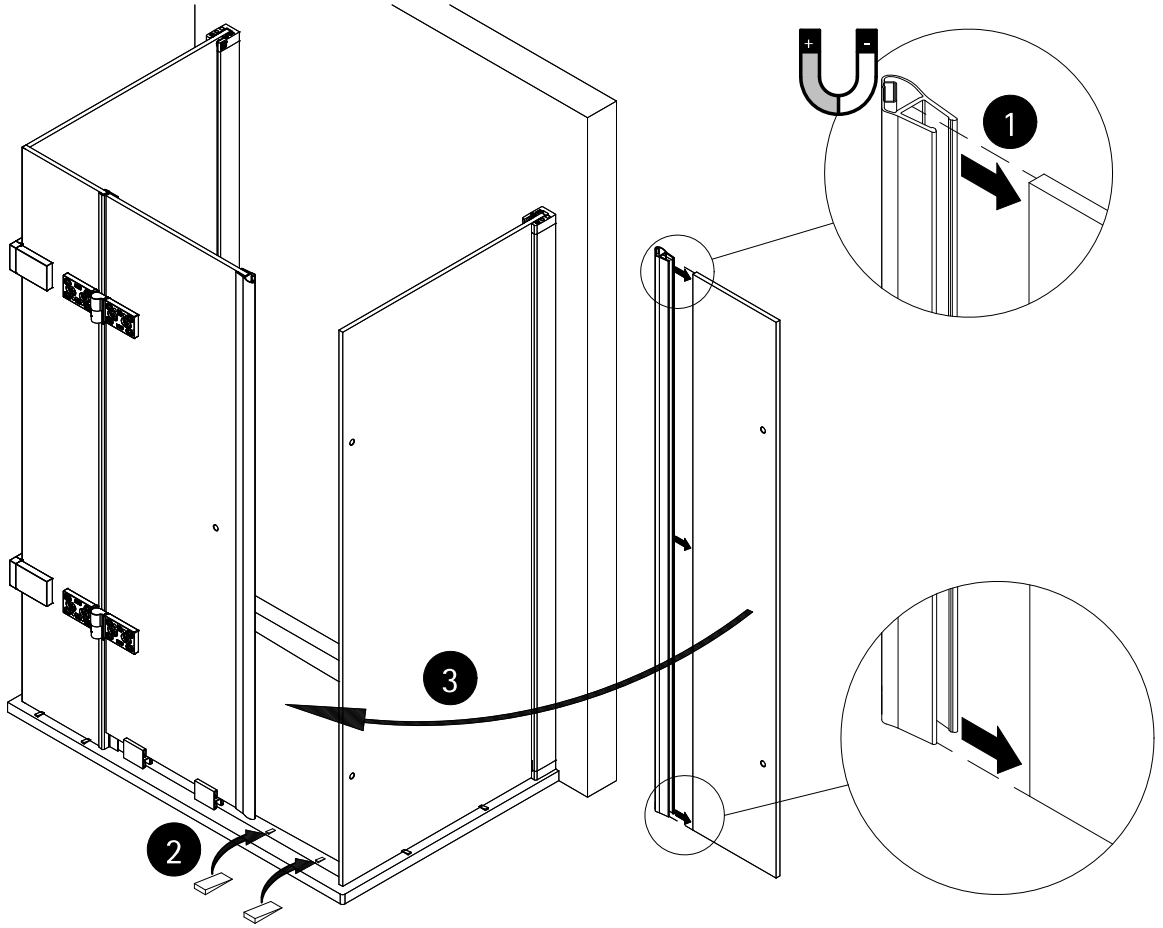

14

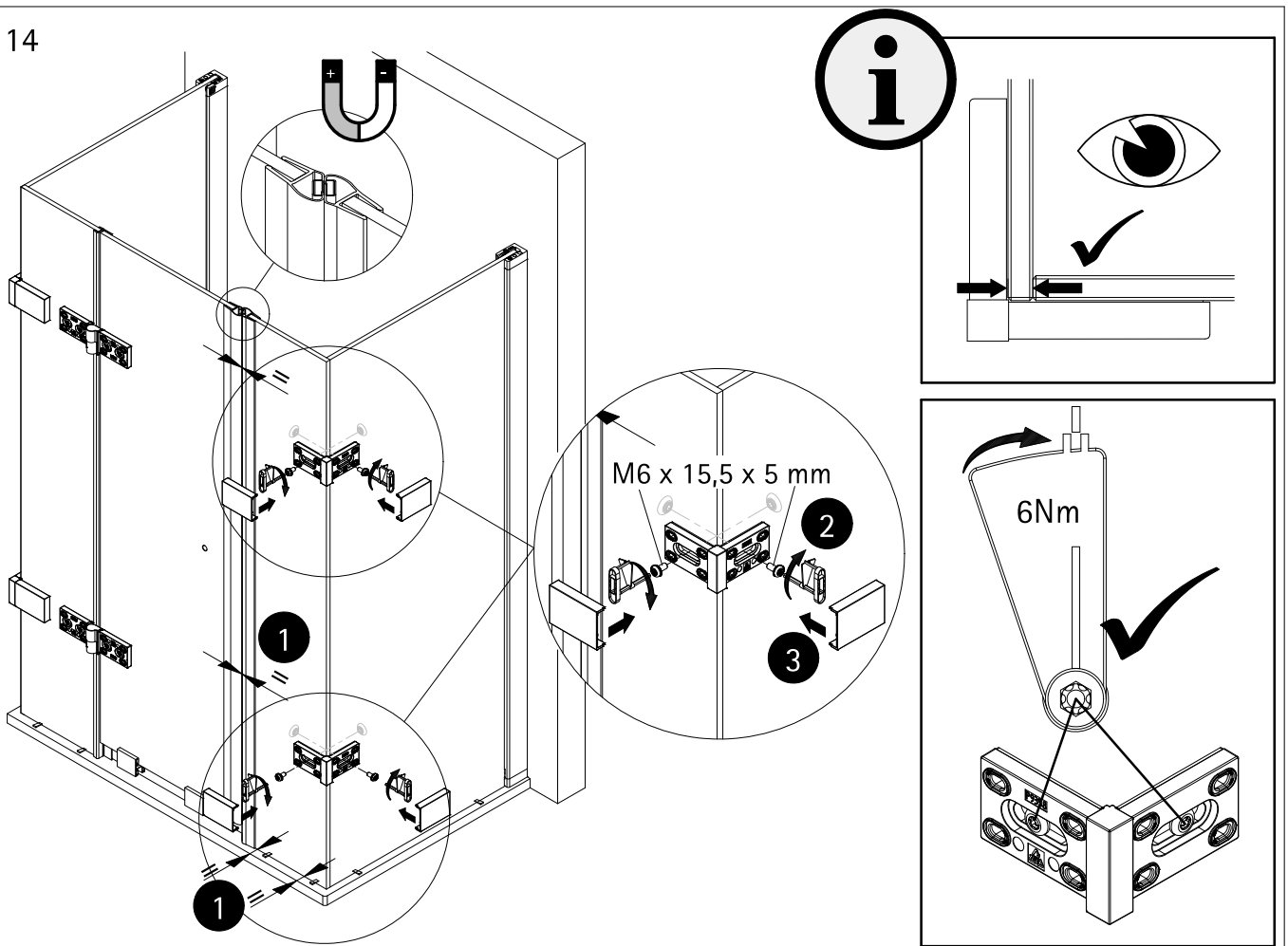

15

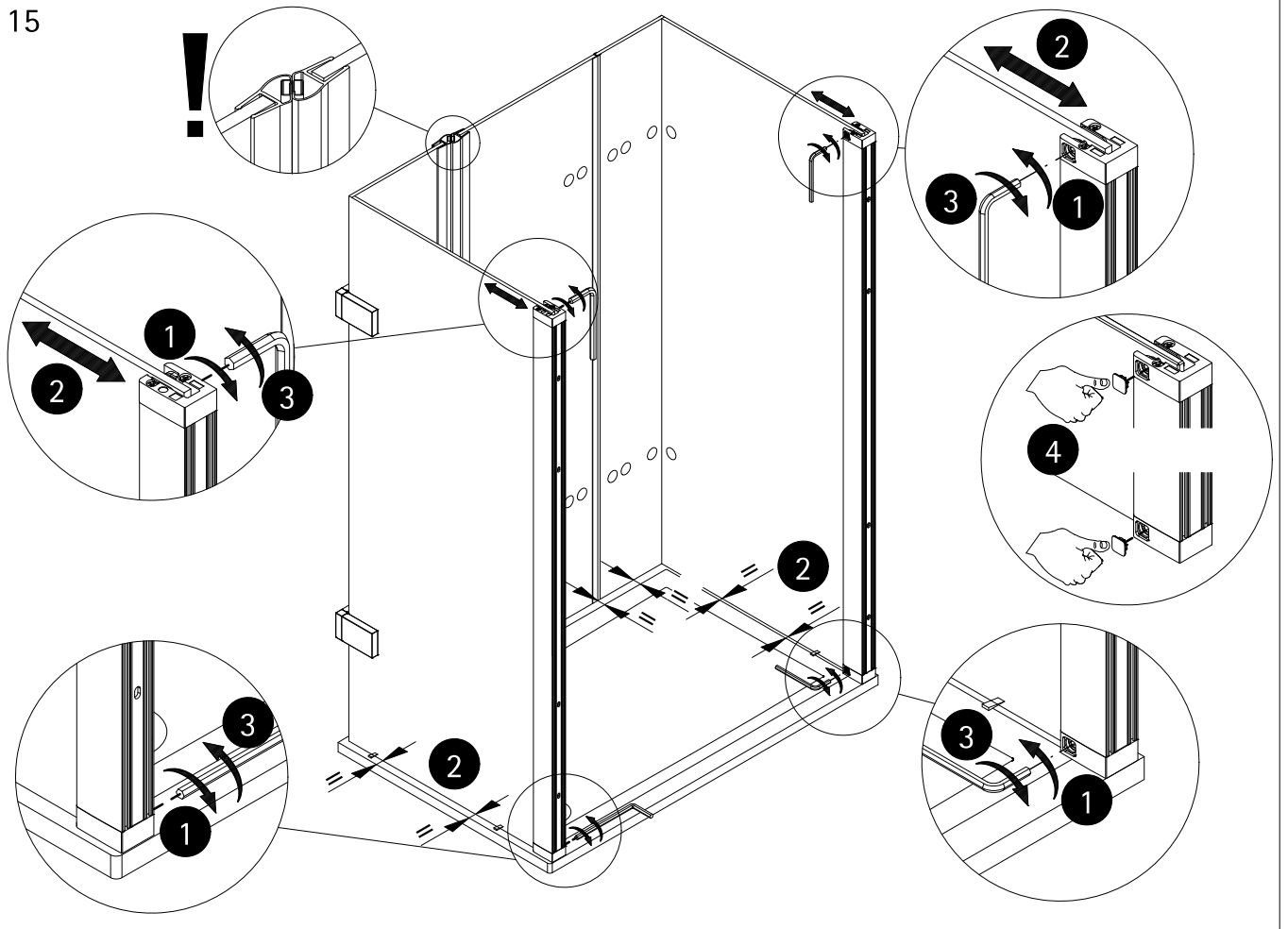

16

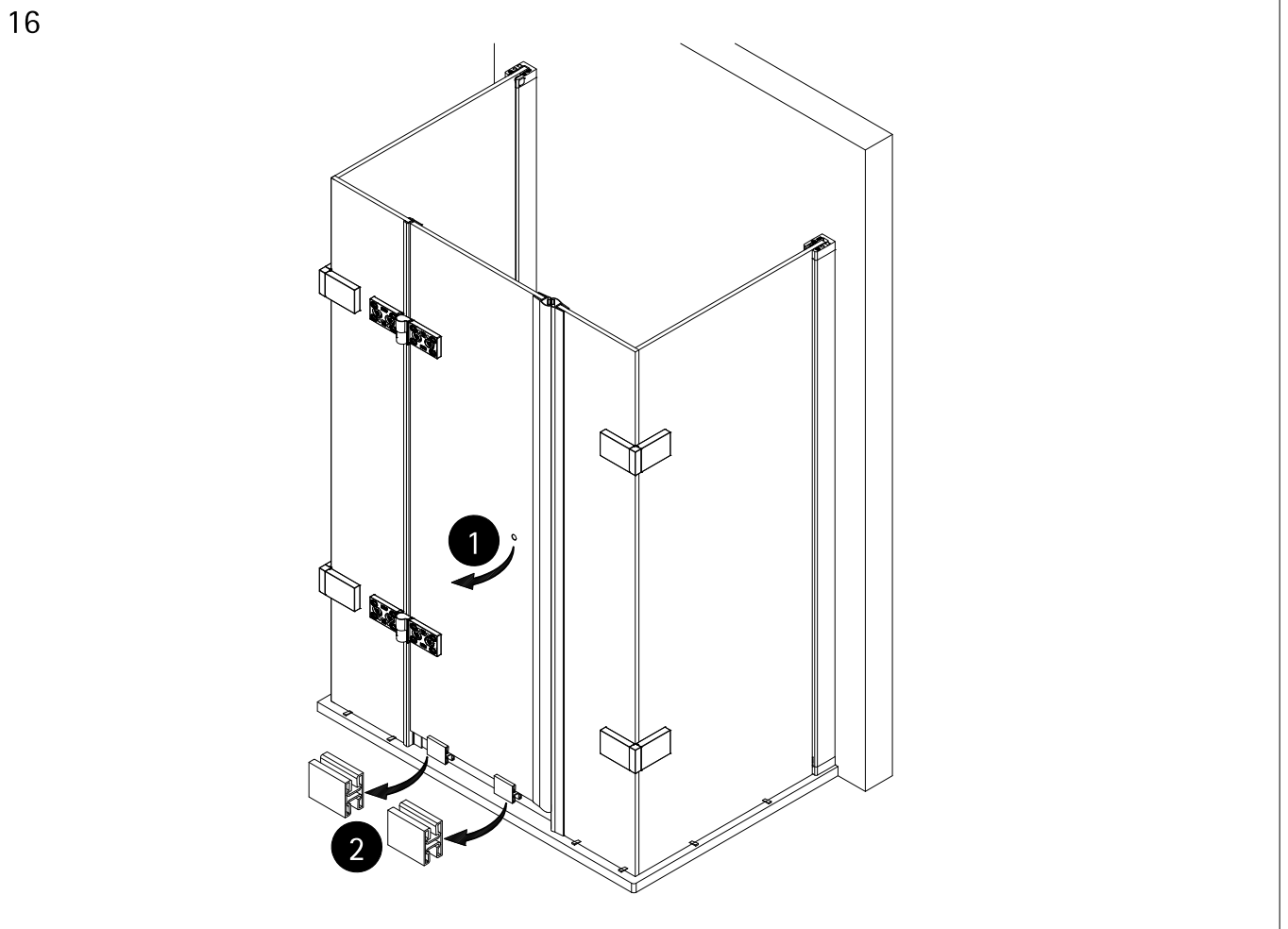

17

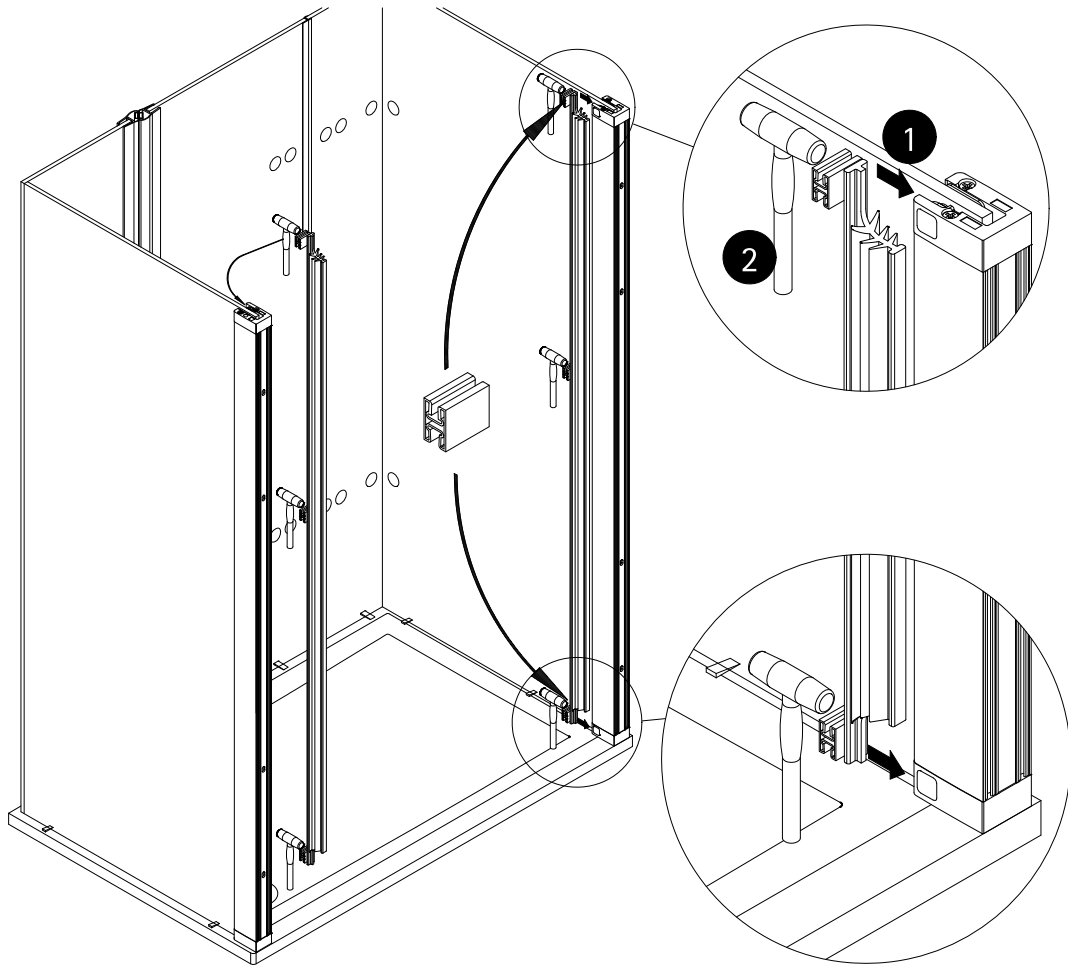

18

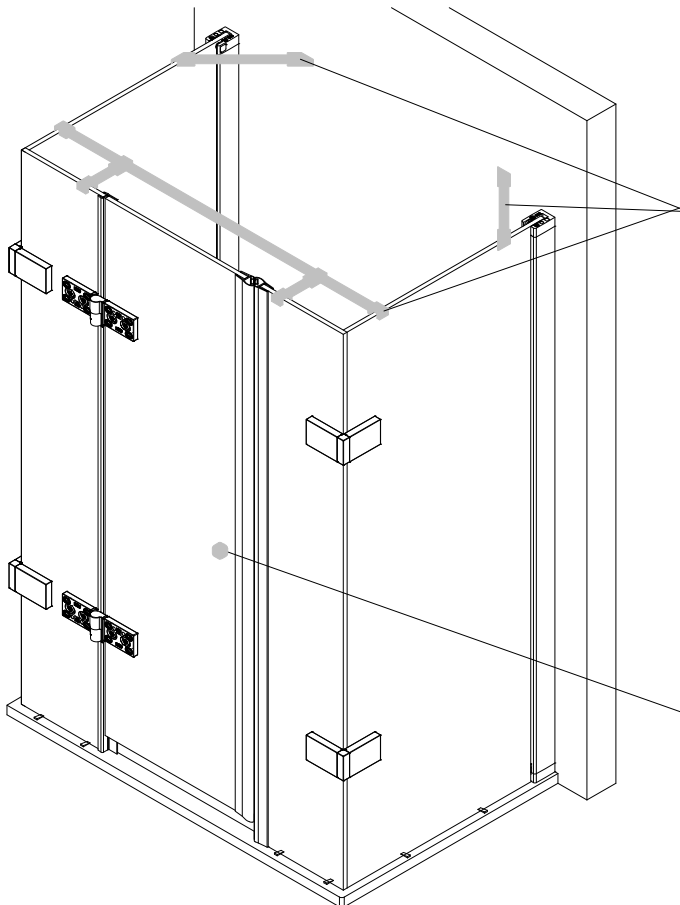

- Die Montage des Stabilisationsbügel entnehmen sie dem Zusatzblatt.
- Please look at the additional sheet for the installation of the stabilizing bar.
- Pour le montage de la barre de stabilisation, consultez la feuille annexe.
- Voor de installatie van de stabilisatie stang zie aanvullende blad.

- Die Montage des Griffes entnehmen sie dem Zusatzblatt.
- Please look at the additional sheet for the installation of the handle.
- Pour le montage de la poignée, consultez la feuille annexe.
- Voor de installatie van de greep zie aanvullende blad.

19

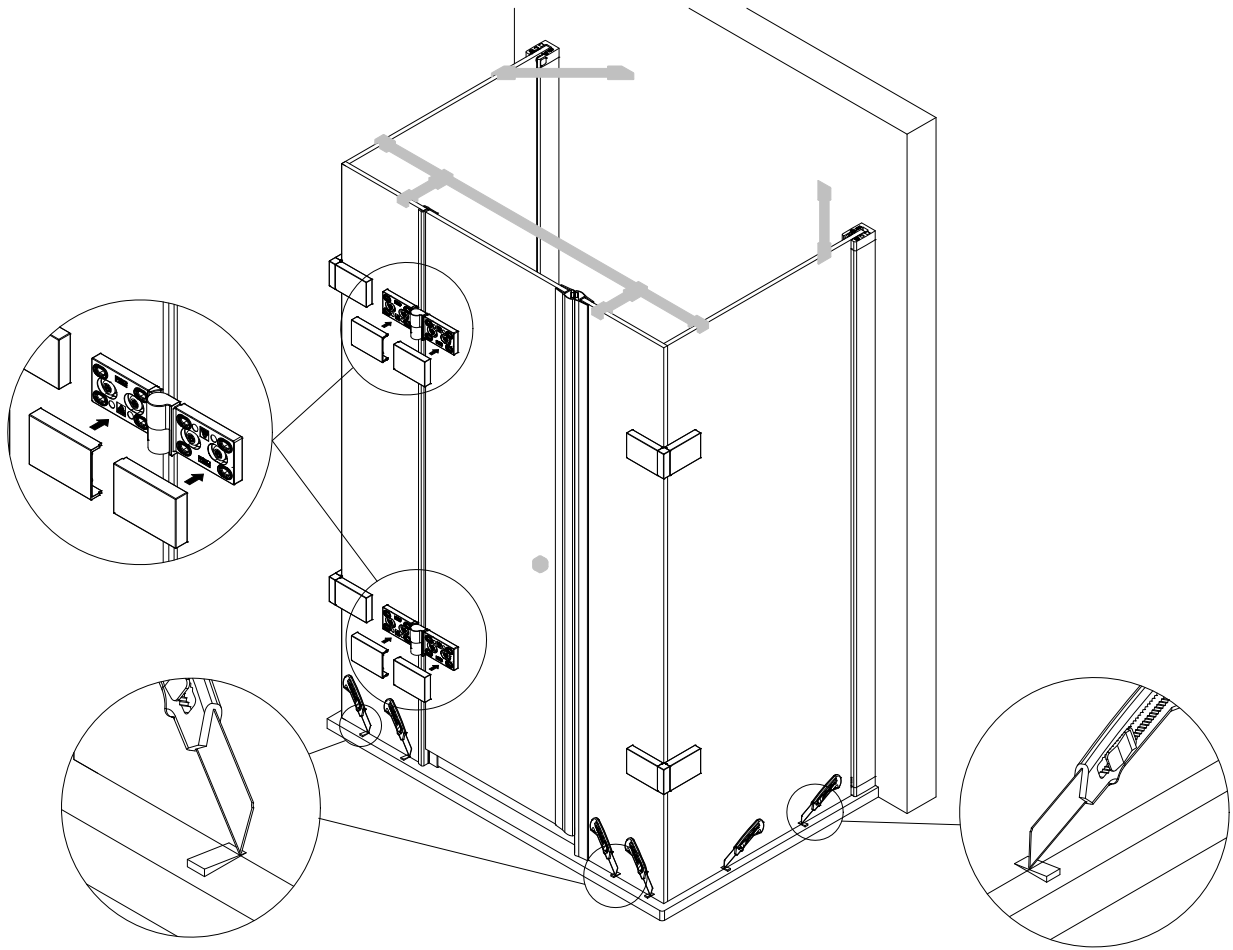

20

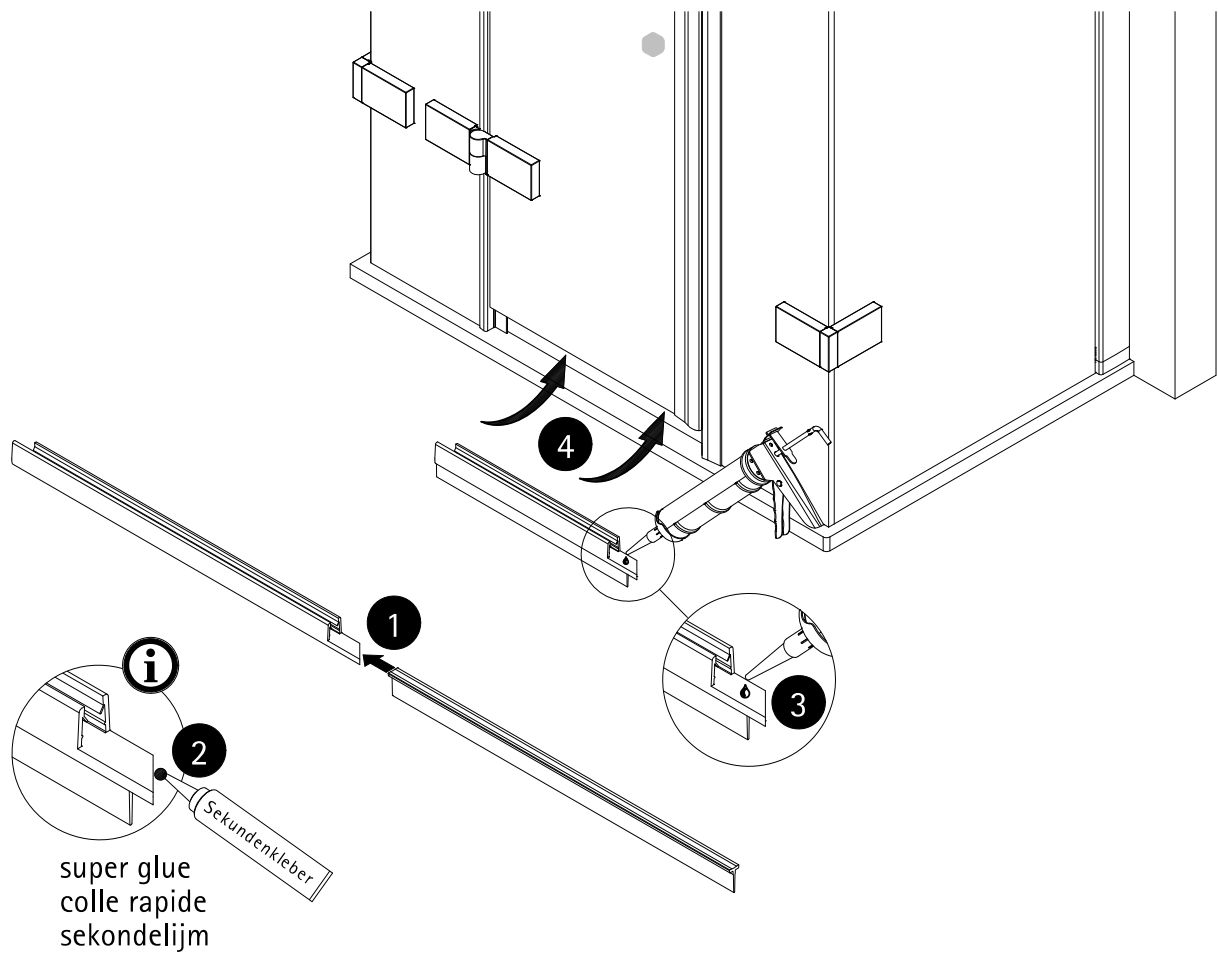

21

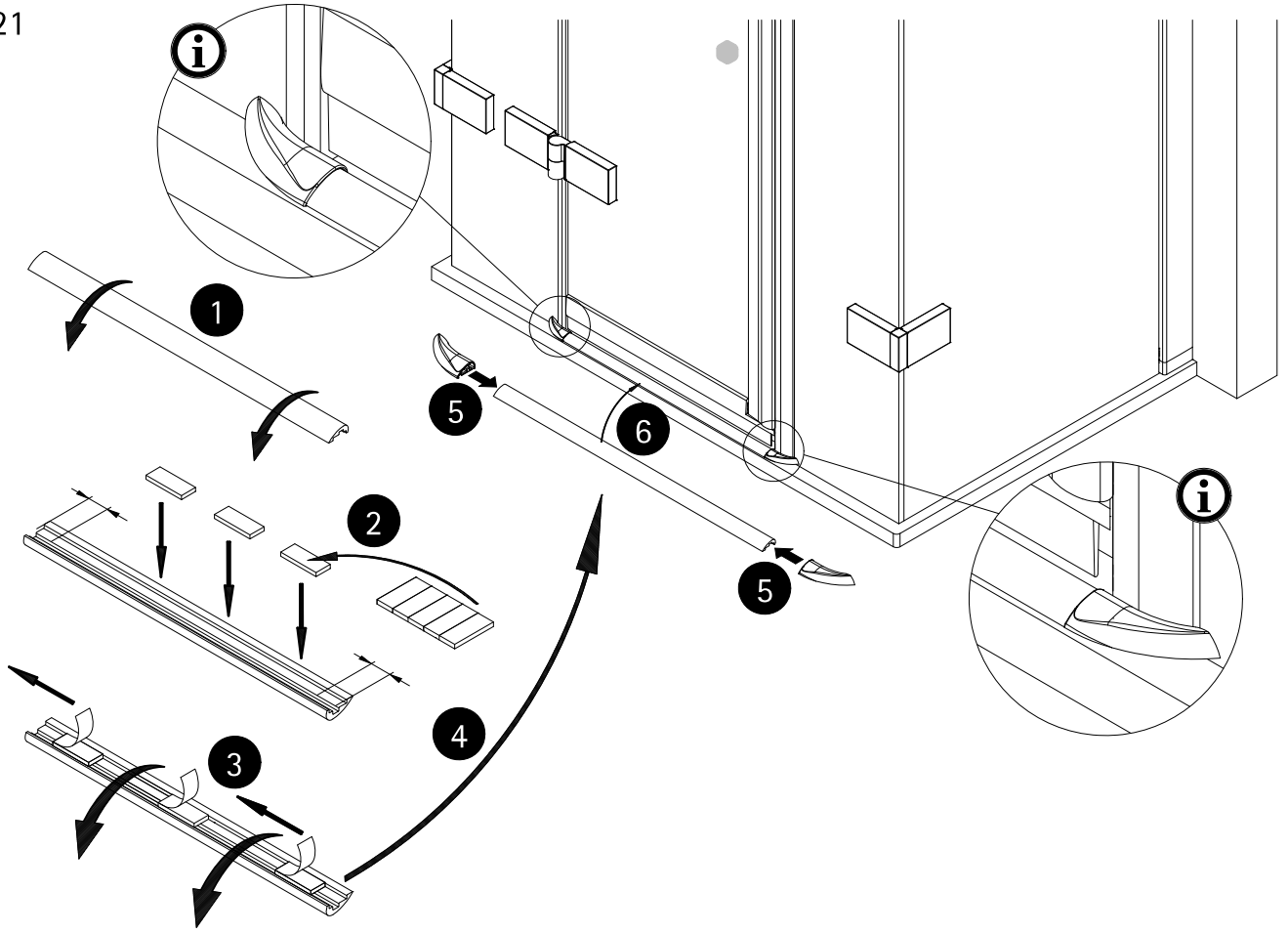

22

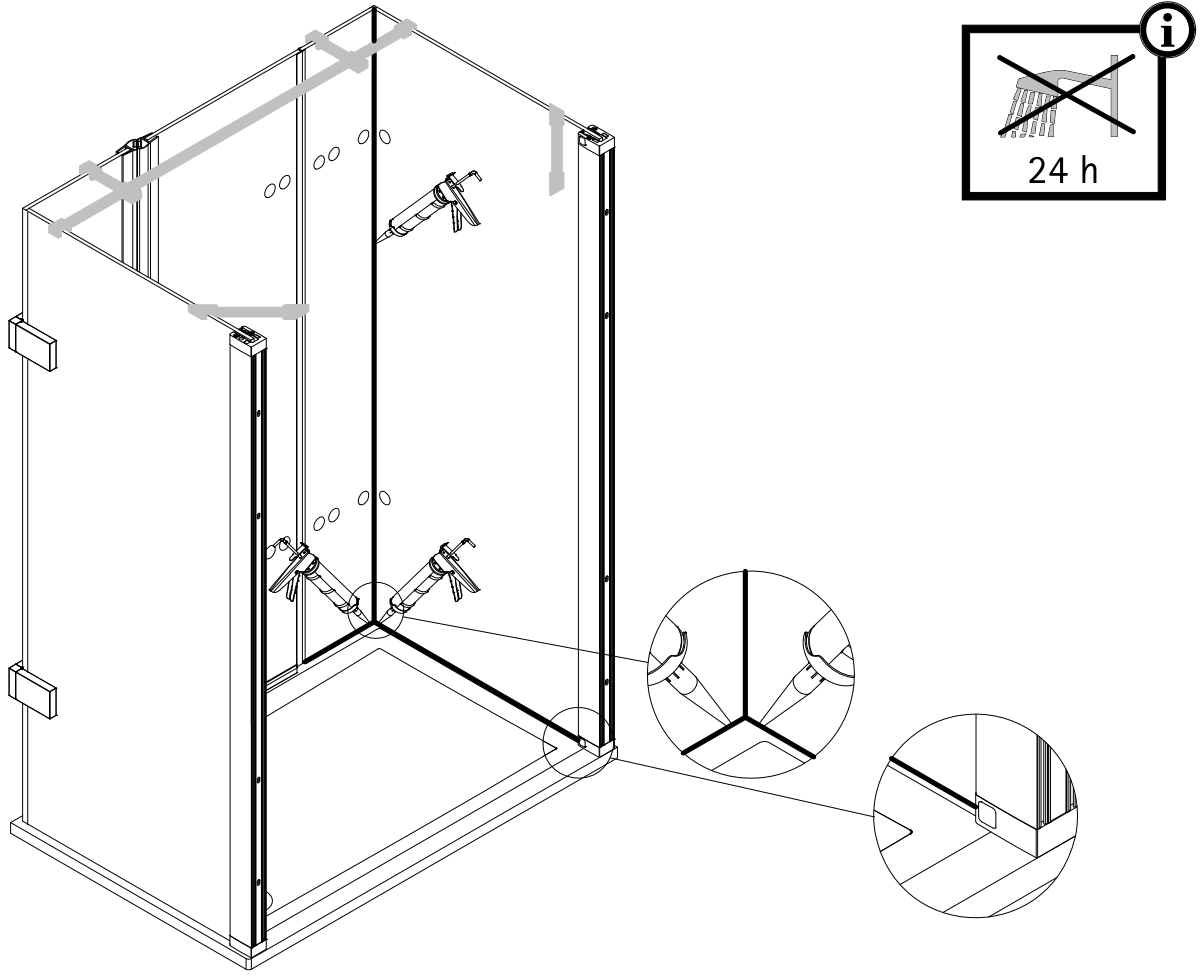

23

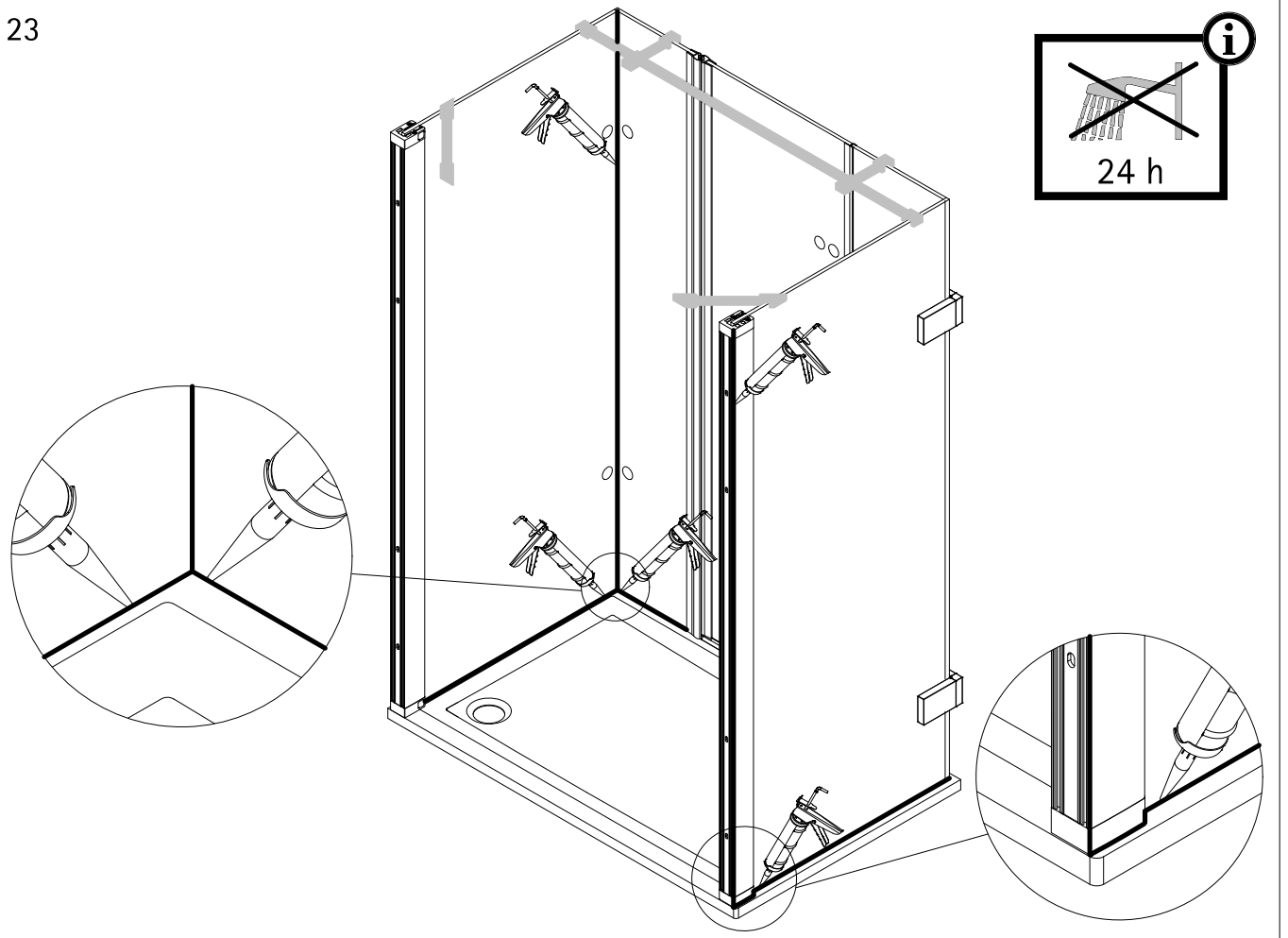

24

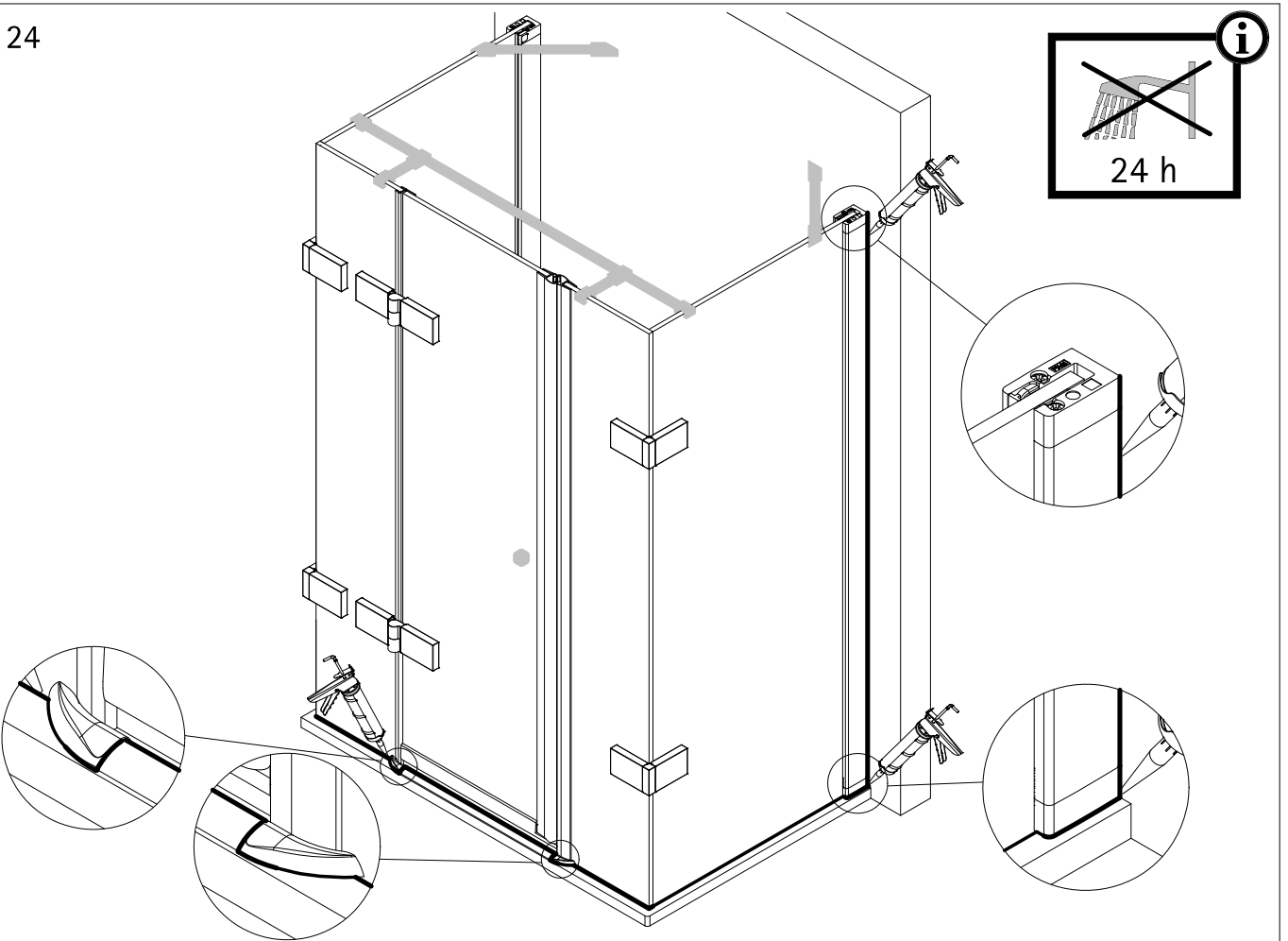

D Wichtiger Hinweis:
Duschkabinen bitte vor dem Einbau auf Transportschäden und Vollständigkeit prüfen, da Beanstandungen nach dem Aufbau nicht mehr anerkannt werden können.

GB Important information:
Please check the shower enclosure for transport damage and completeness before installation. Complaints made following installation cannot be accepted.

F Remarque importante:
avant de procéder au montage, vérifiez que le pare douche est complet et qu'il n'a pas été endommagé lors du transport. Aucune réclamation ne pourra être admise après le montage.

NL Belangrijk:
Controleer voor het inbouwen of het douchescherm bij het transport beschadigd is en of het volledig is. Na het inbouwen kunnen klachten niet meer in behandeling genomen worden.

D Sicherheitshinweis:
Einscheiben-Sicherheitsgläser nie nachträglich bearbeiten.

GB Safety information:
Single pane, safety glass panels must not be reworked in any way following supply.

F Remarques concernant la sécurité:
Vous ne devez en aucune façon tenter de retailler les vitrages en verre sécurité.

NL Veiligheidsvoorschrift:
Gehard veiligheidsglas mag niet achteraf worden bewerkt.



| |
|--|
| CE |
| Dusch-Info Meerpfad 27-31 56566 Neuwied Tel.: 02631-8607-0 Fax: 02631-860735 18 |
| EN 14428 |

D Duschabtrennung aus einem bestimmten Scheibenmaterial

| | |
|---------------------|-----------|
| Reinigbarkeit: | Bestanden |
| Brucheigenschaften: | Bestanden |
| Dauerhaftigkeit: | Bestanden |

F Paroi de douche dans un matériau vitré particulier

| | |
|--------------------------|-------------------|
| Nettoyabilité: | passé avec succès |
| Propriétés à la cassure: | passé avec succès |
| Durabilité: | passé avec succès |

GB Shower enclosure made of a specific plane material

| | |
|---------------------|--------|
| Cleanability: | Passed |
| Fracture behaviour: | Passed |
| Durability: | Passed |

NL Douche-afschieding van bepaald ruitmateriaal

| | |
|---------------------|-----------|
| Reinigbaarheid: | Doorstaan |
| Breukeigenschappen: | Doorstaan |
| Duurzaamheid: | Doorstaan |