

Montageanleitung Installation instructions Instructions de montage Montagehandleiding

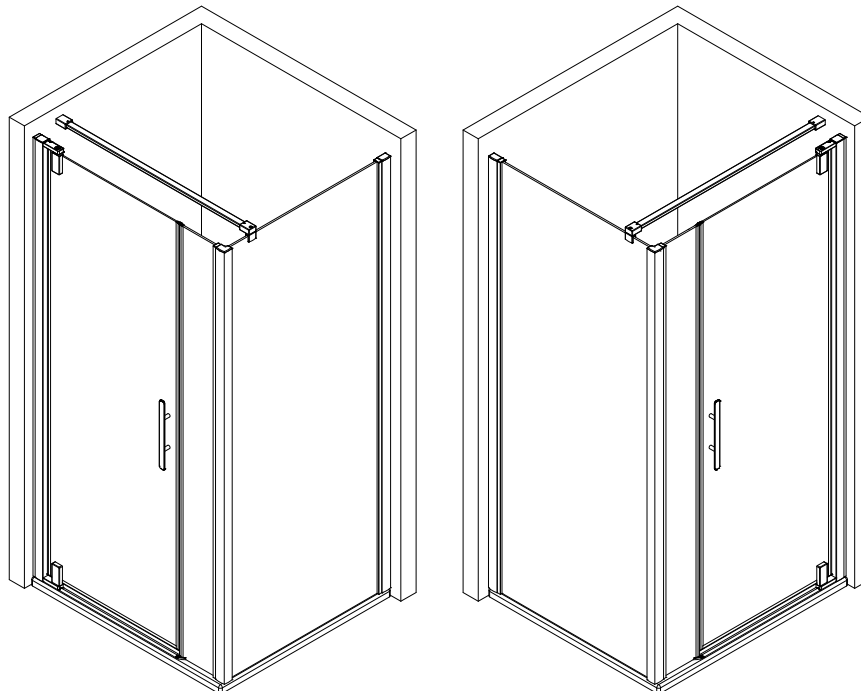

Montageanleitung Installation instructions Instructions de montage Montagehandleiding

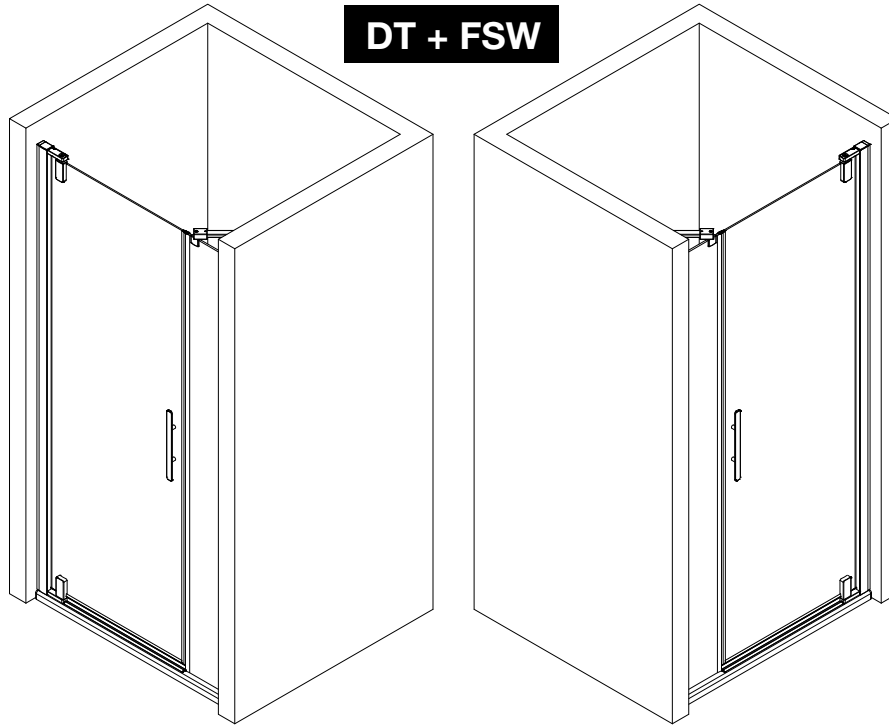

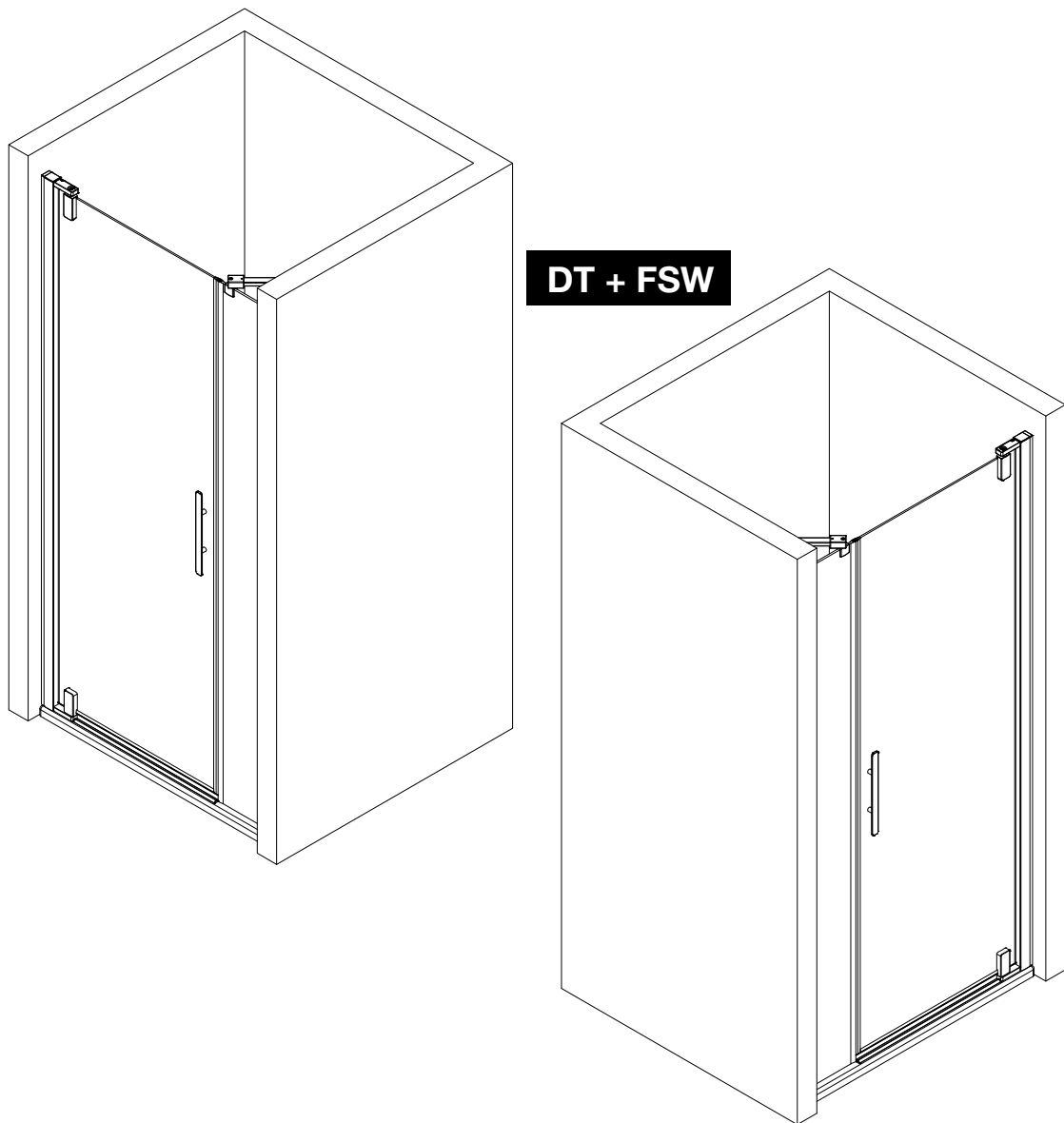
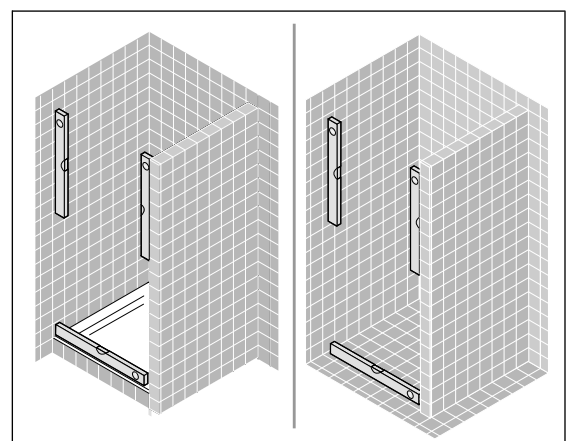
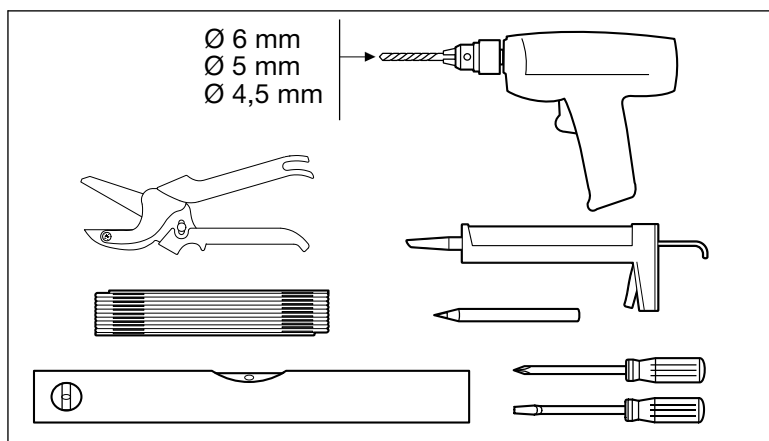
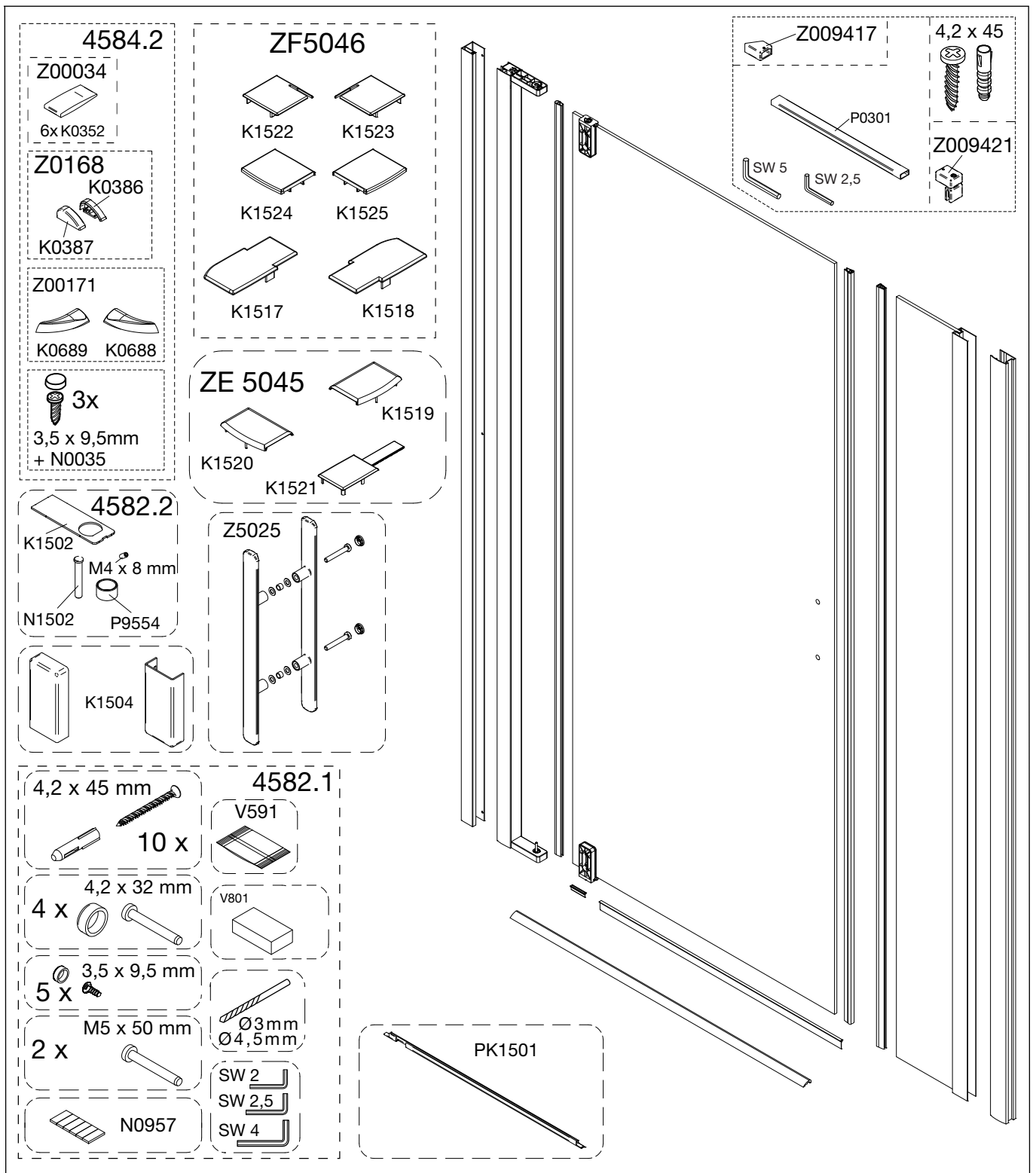

1

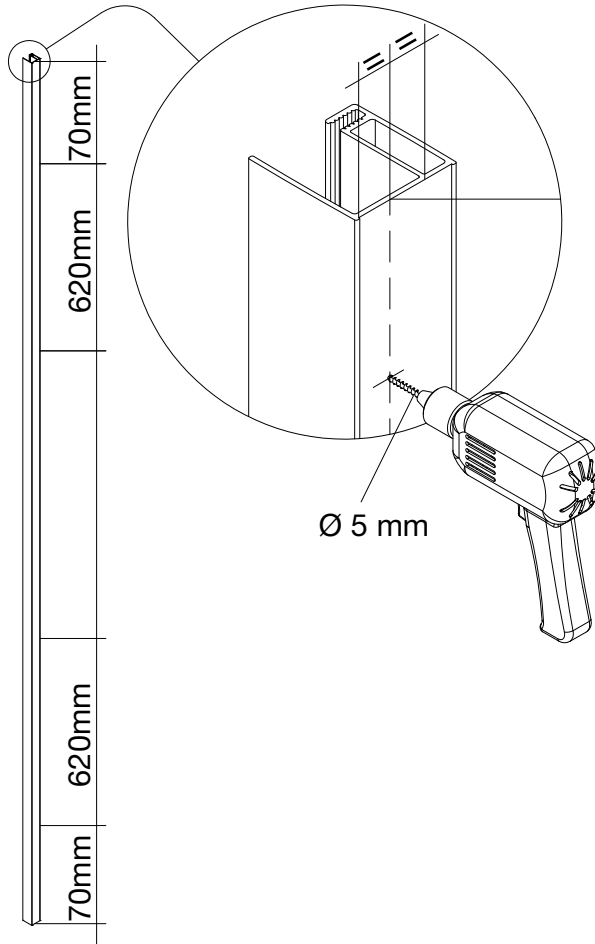

2

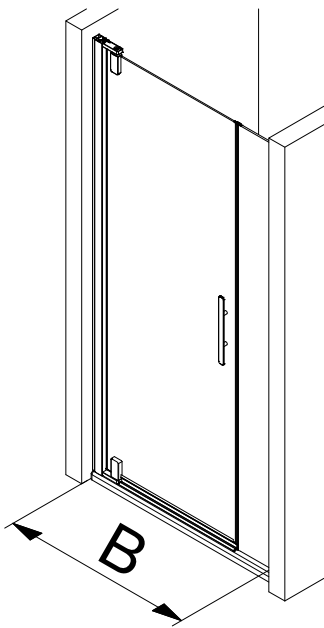

A	B
1200	1175 - 1215
1400	1375 - 1415
1600	1575 - 1615

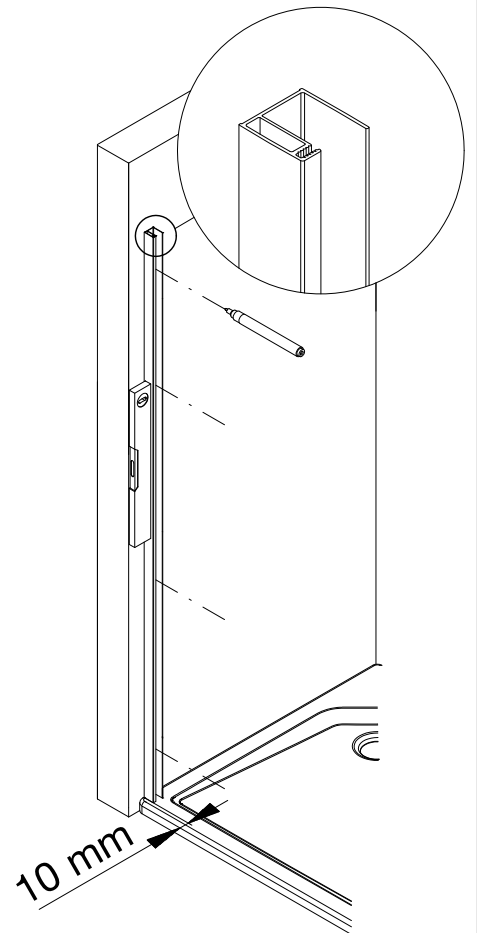
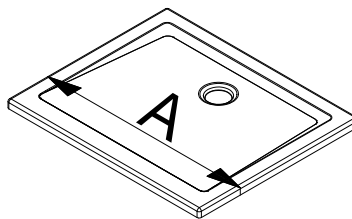

3

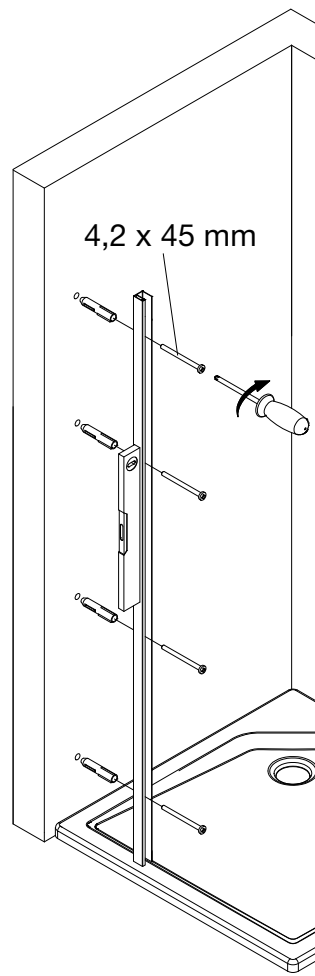
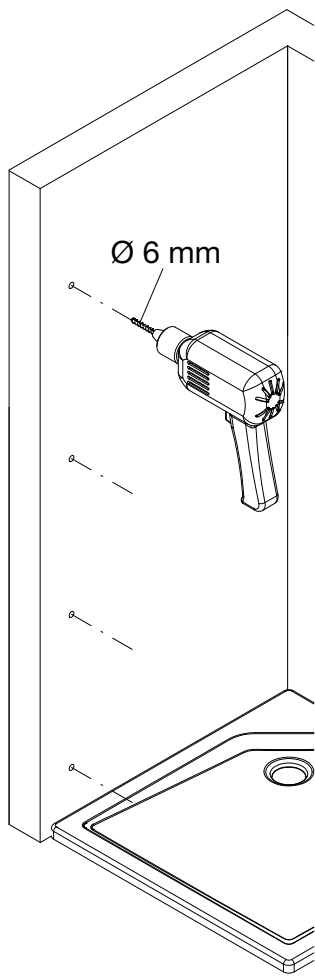
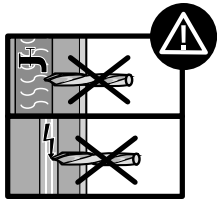

4

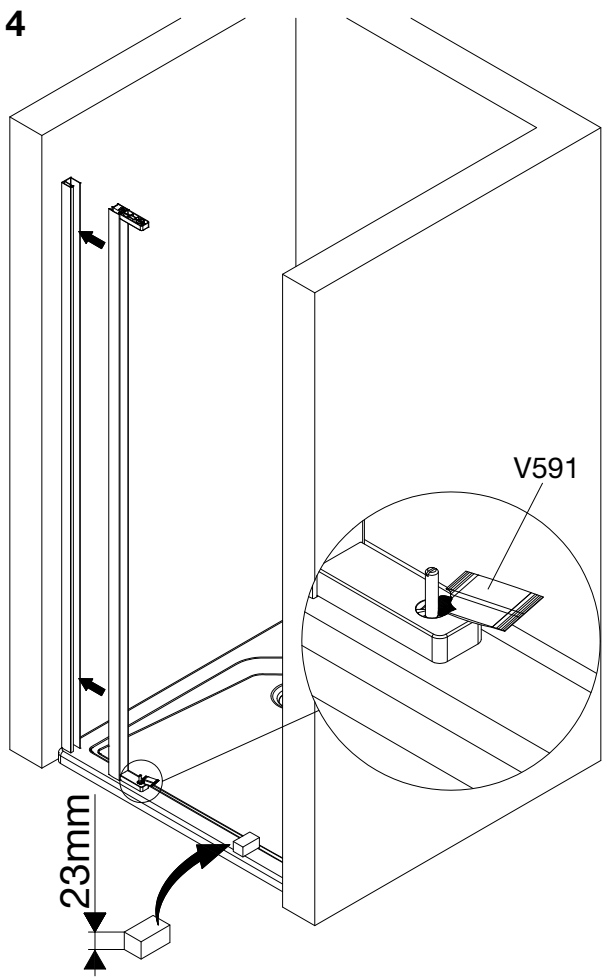

5

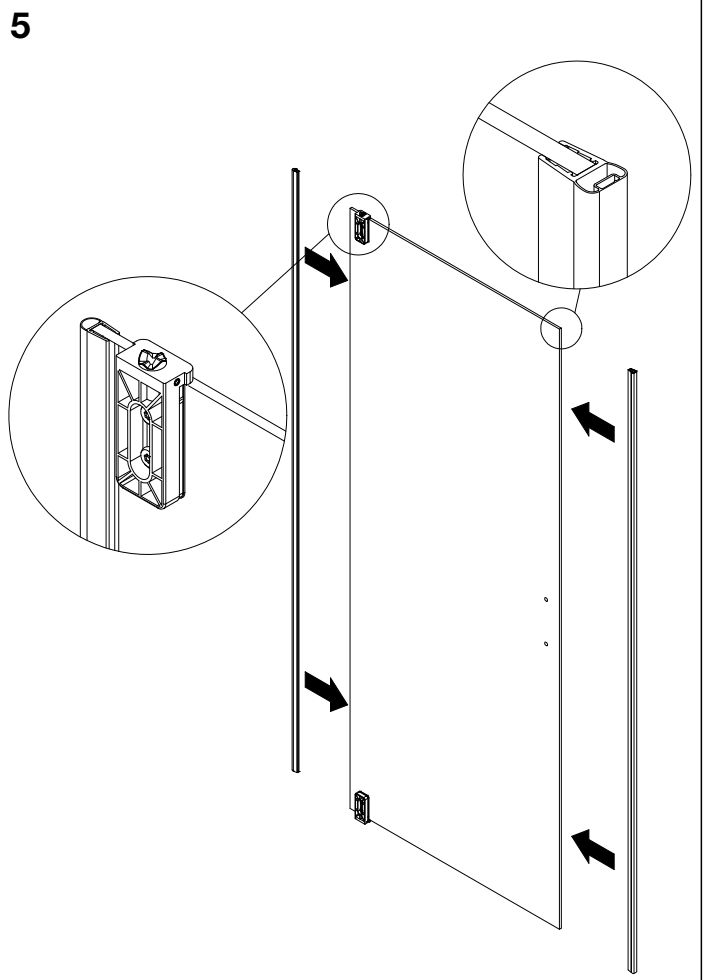

5

6

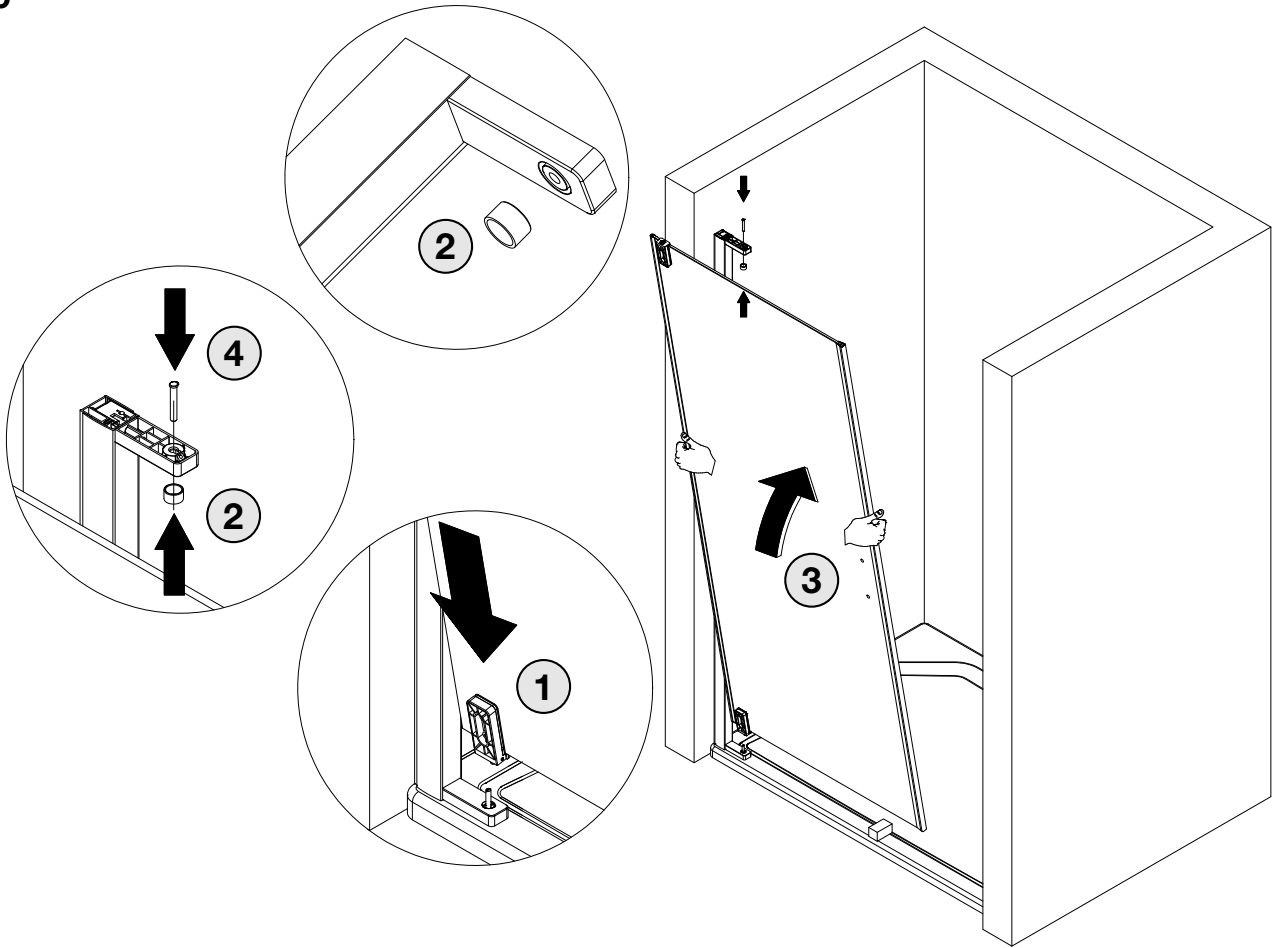

7

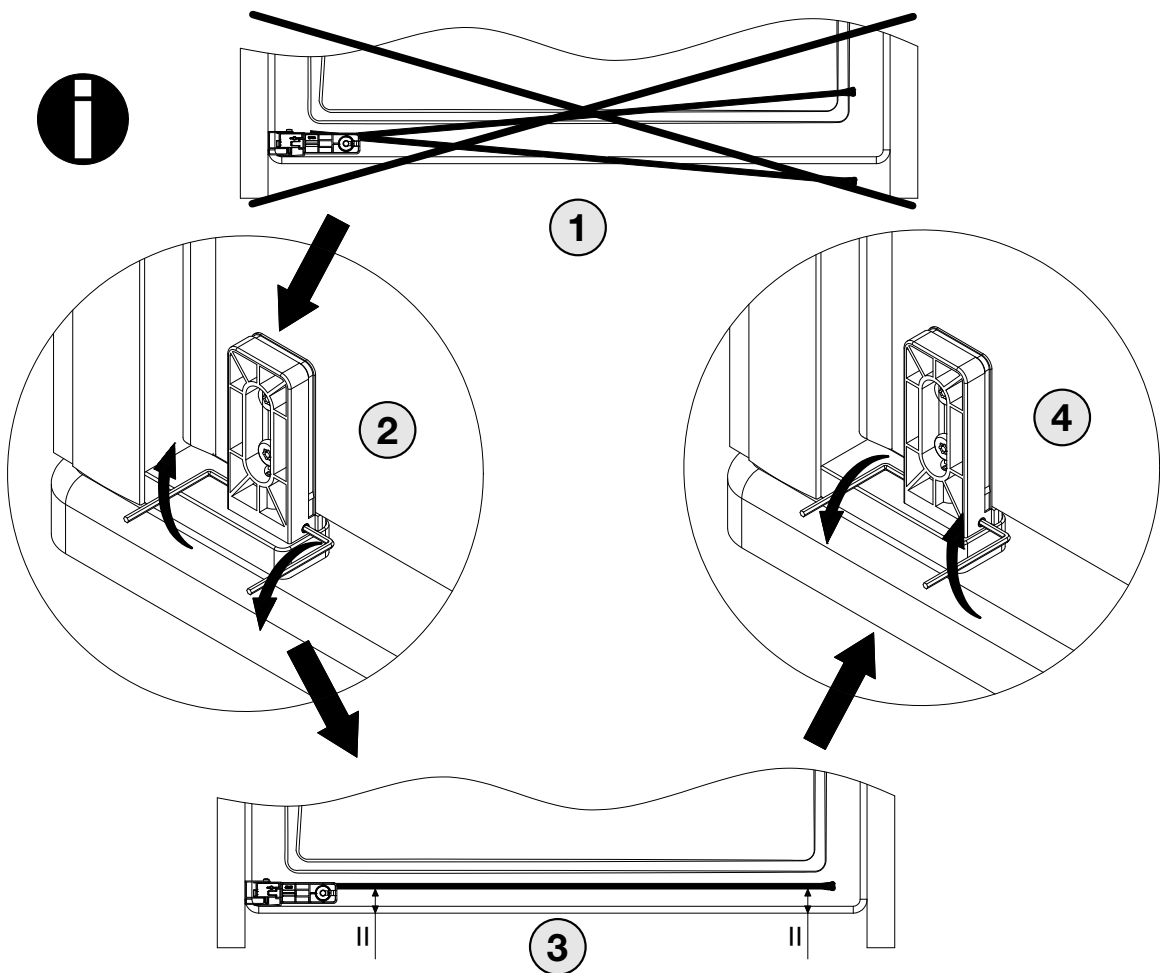

8

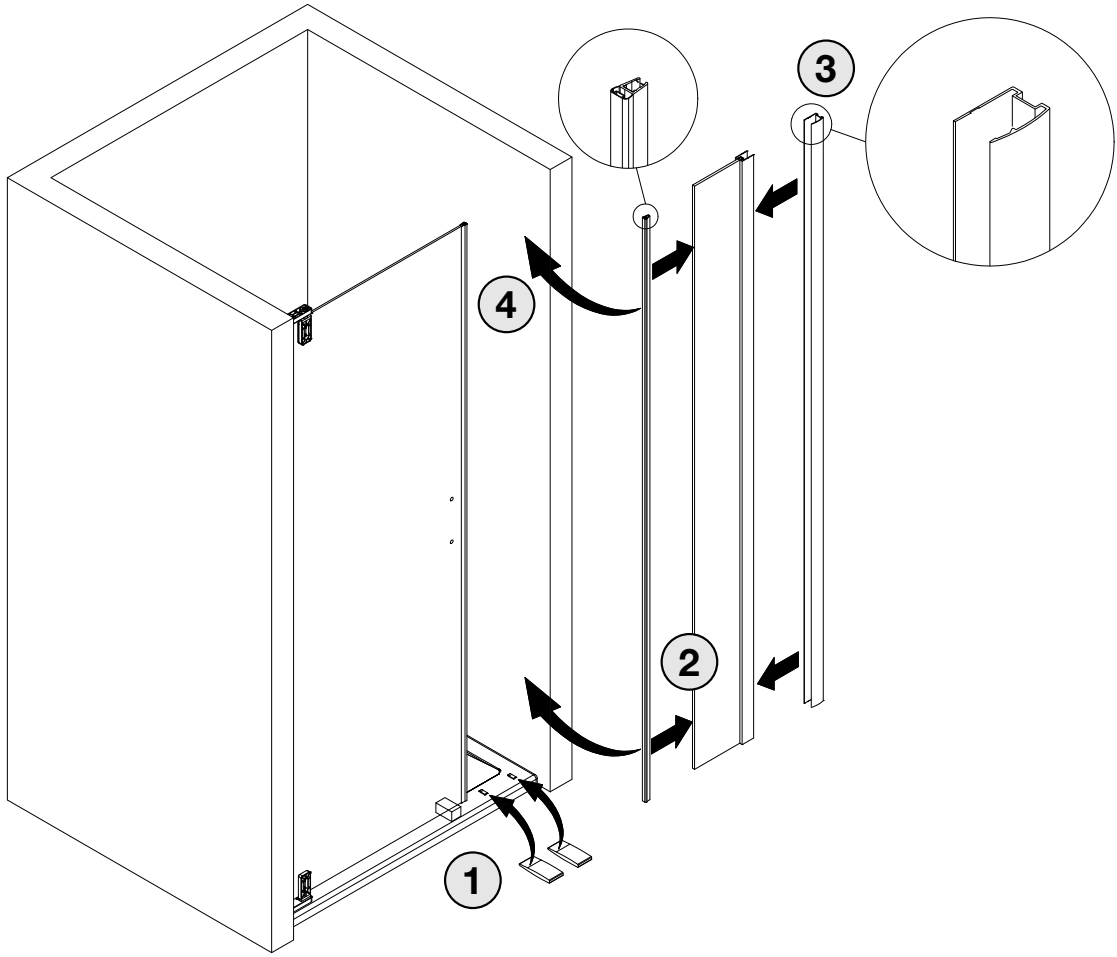

9

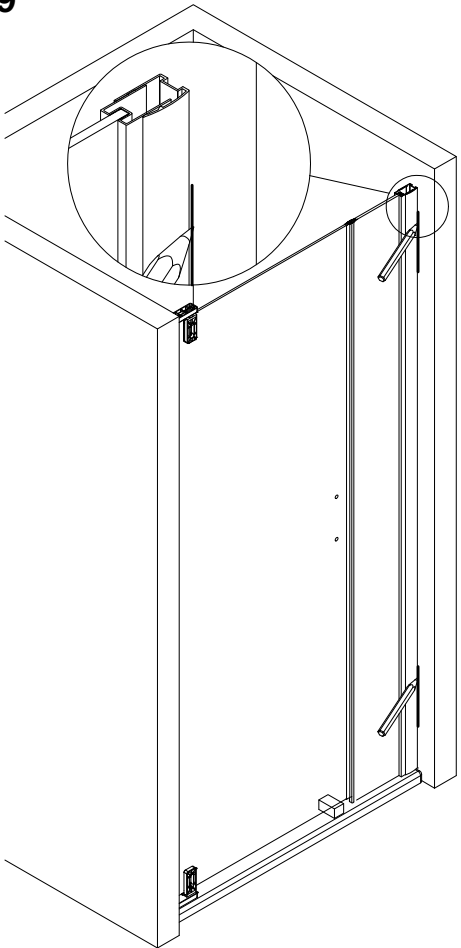

10

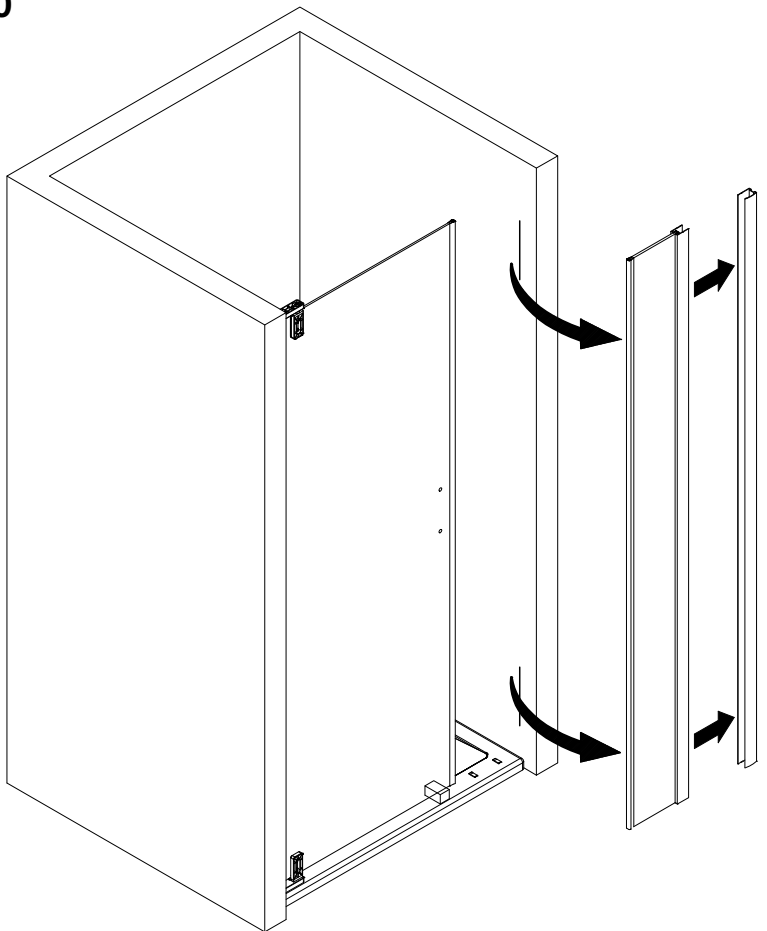

11

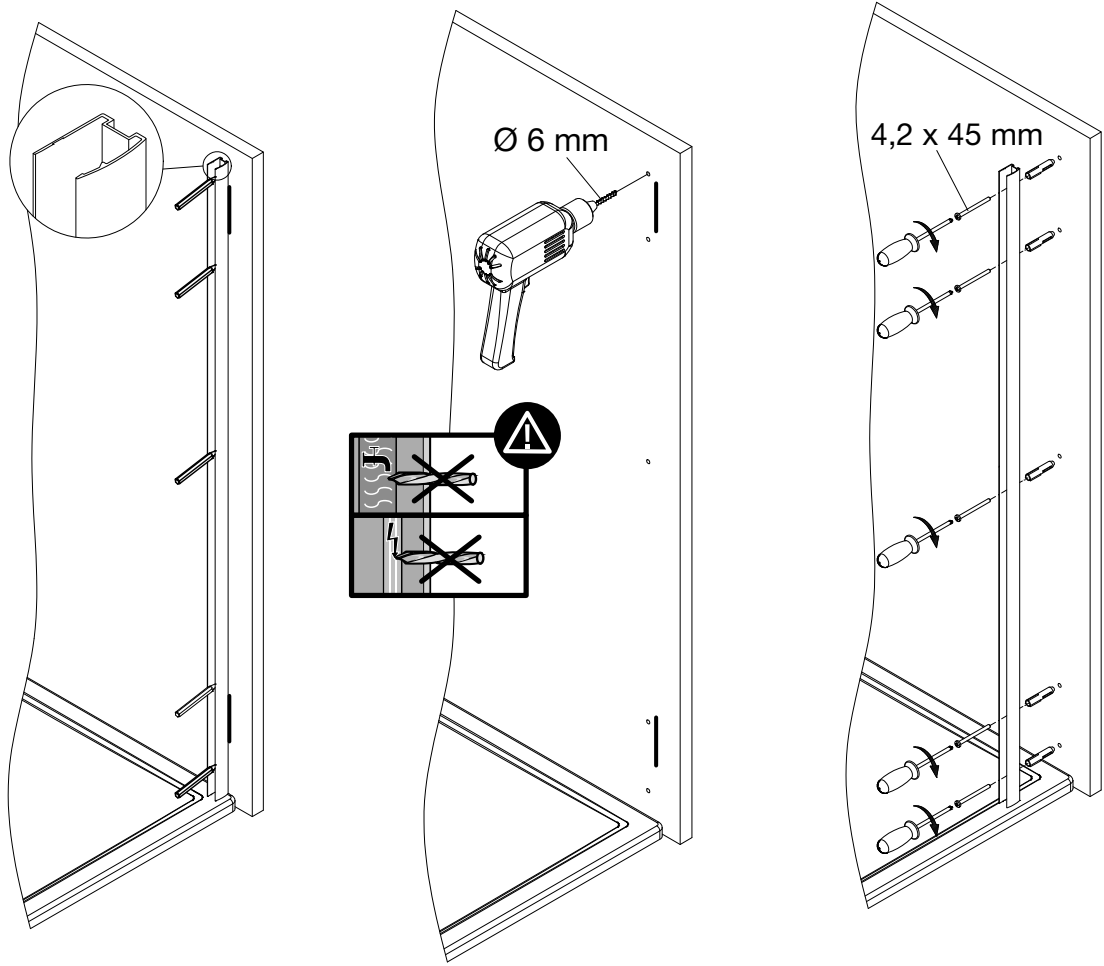

12

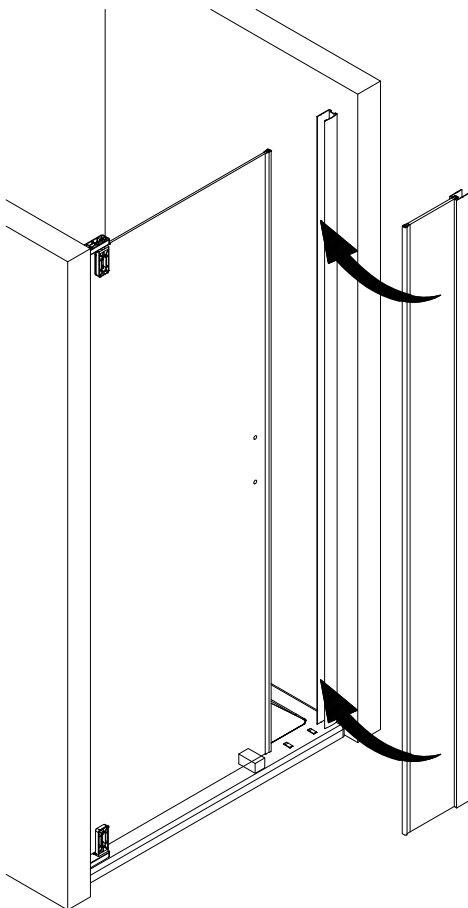

13

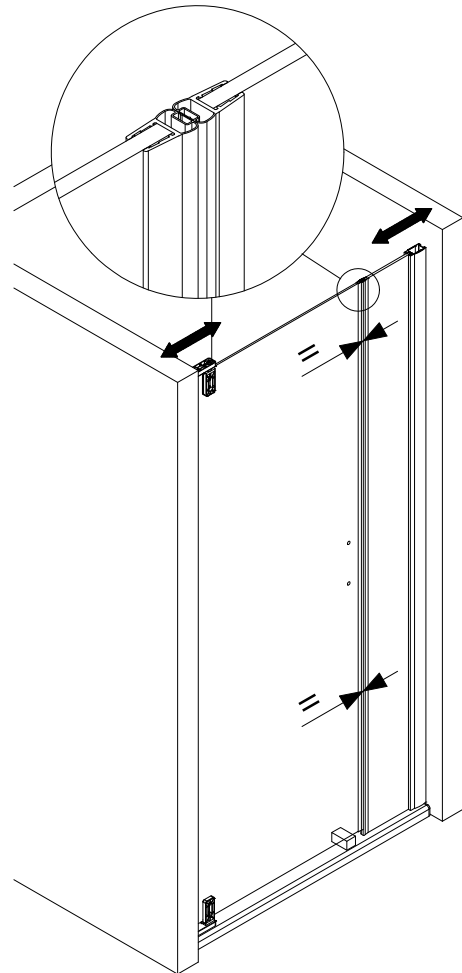

14

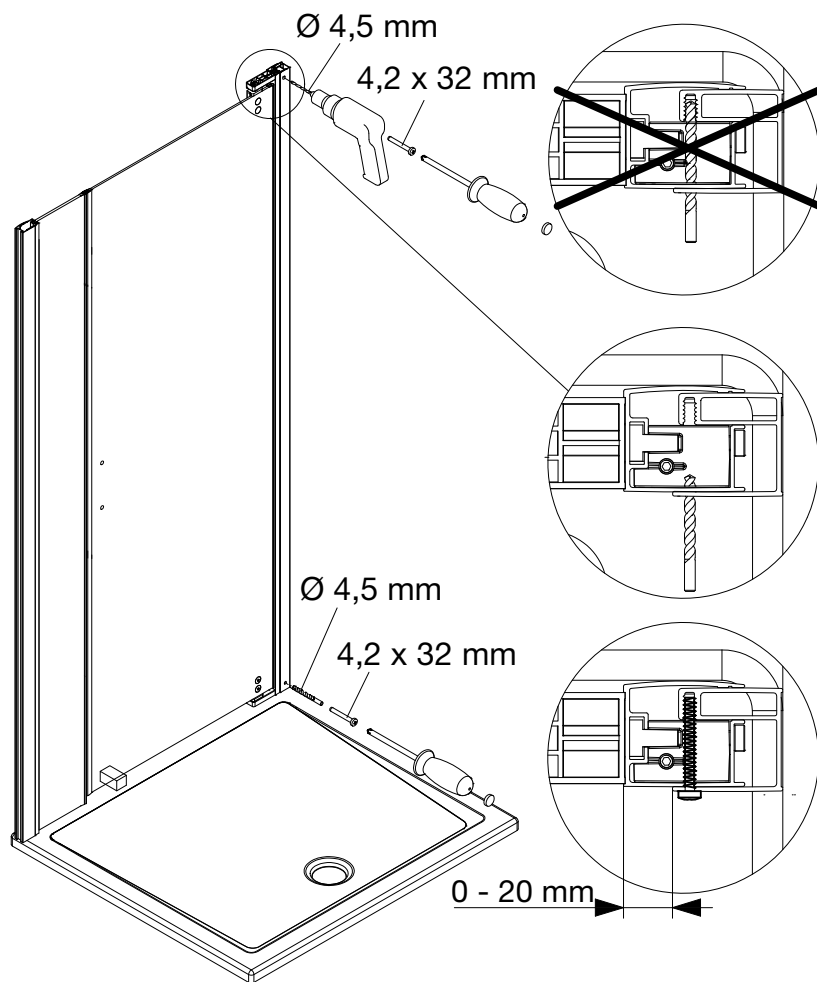

15

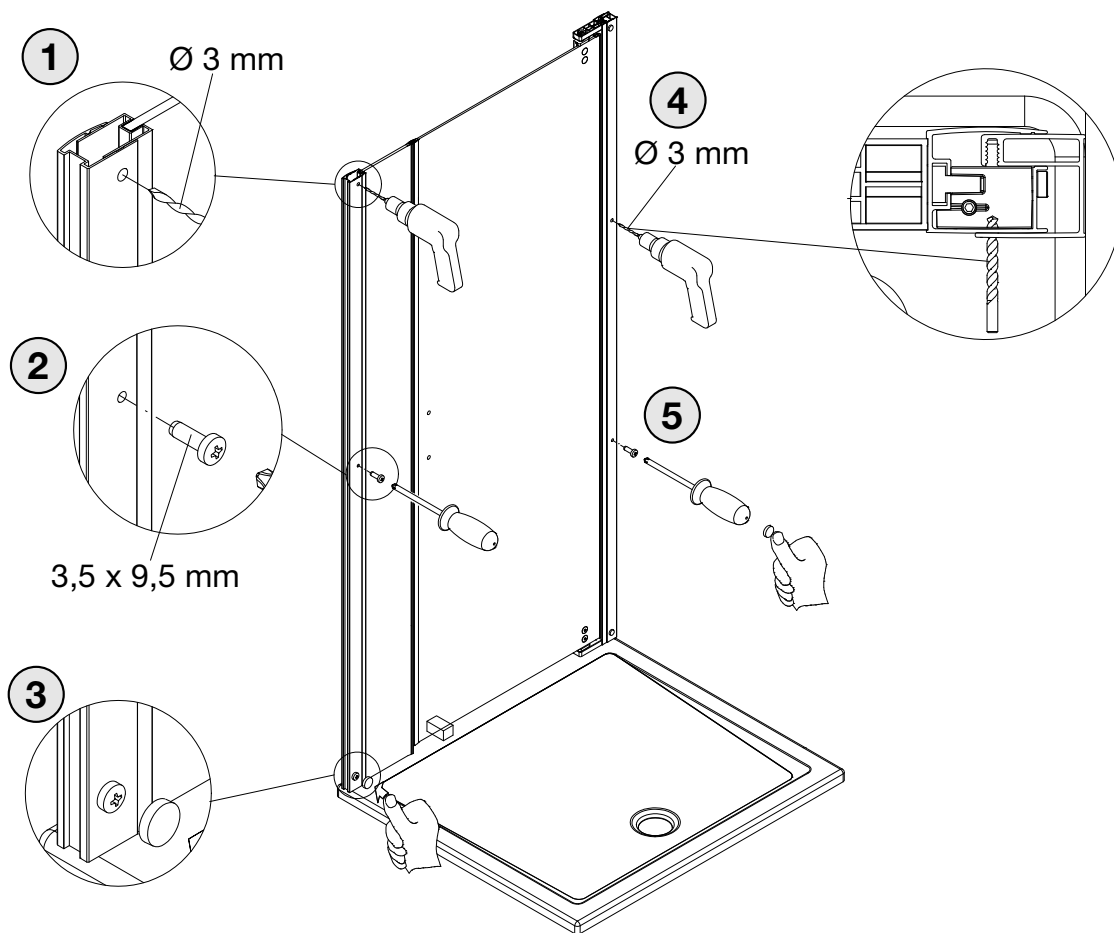

16

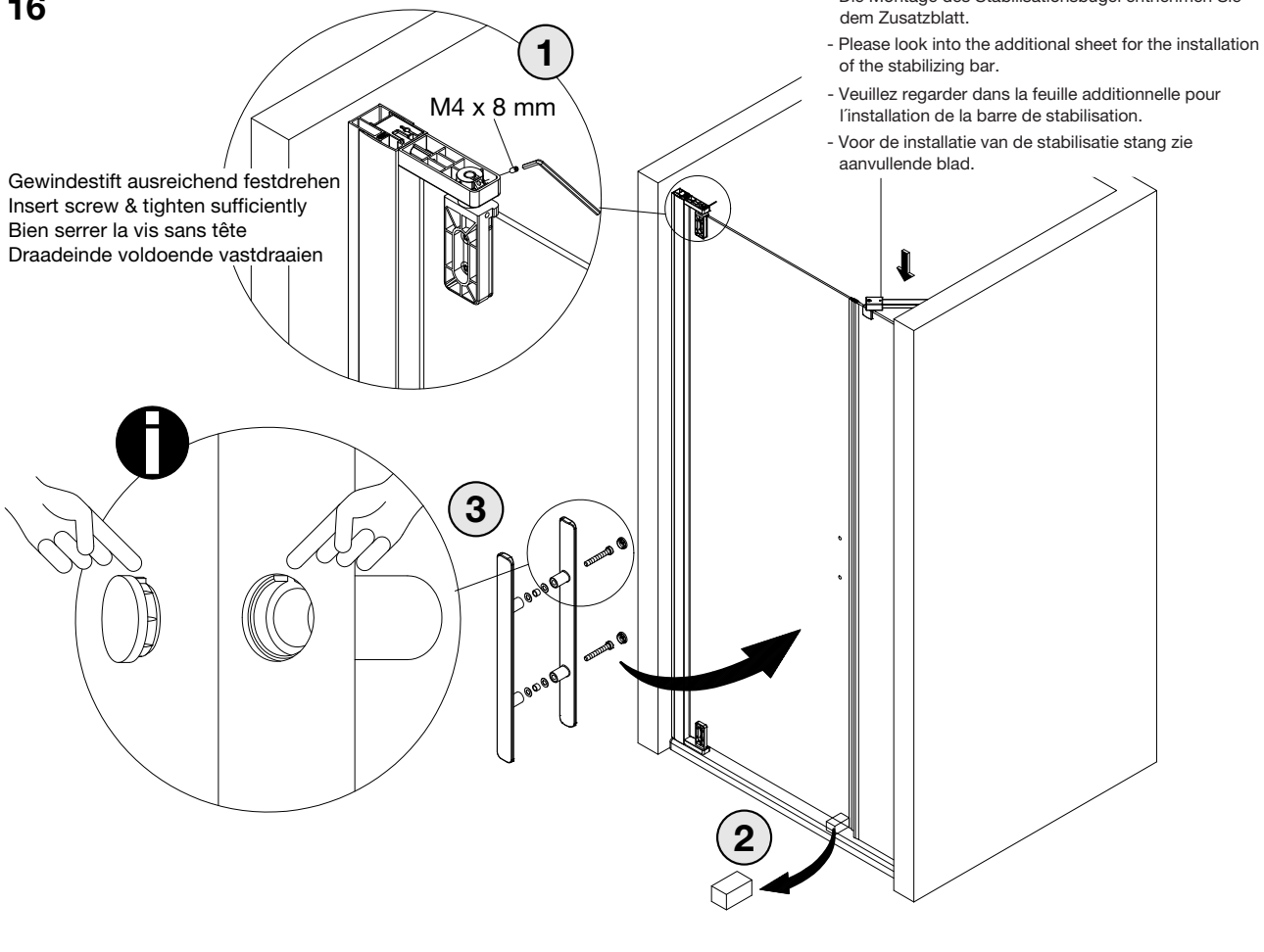

17

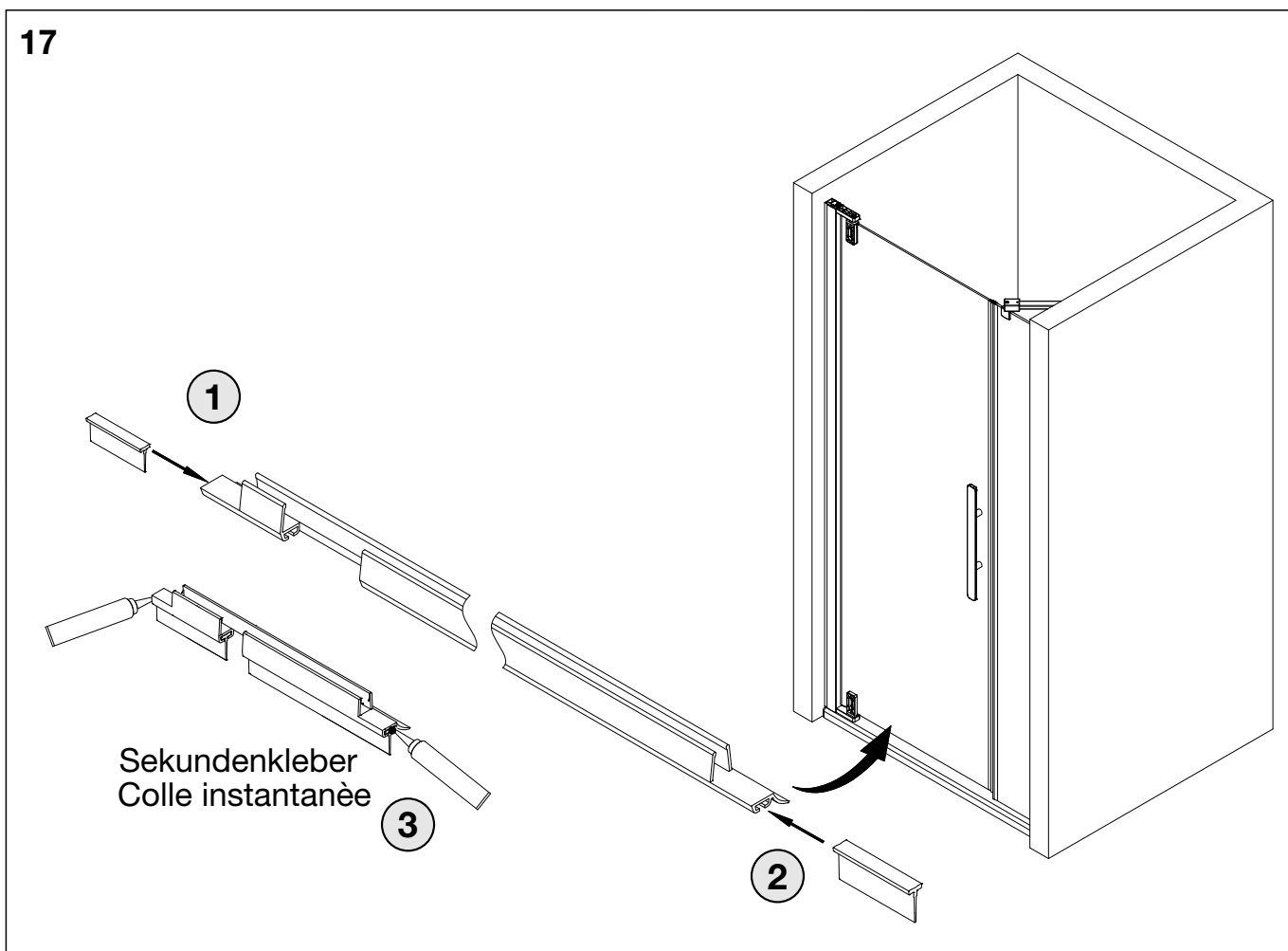

18

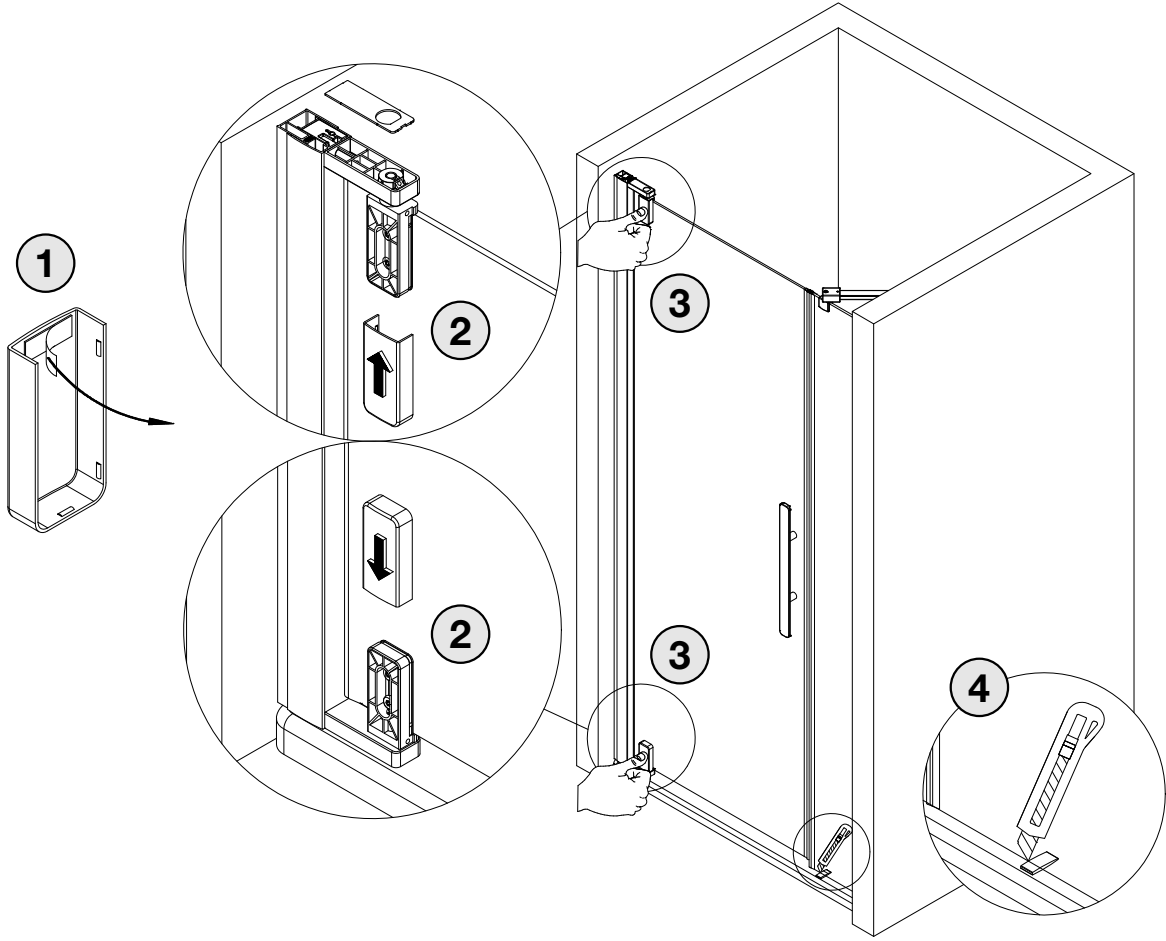

19

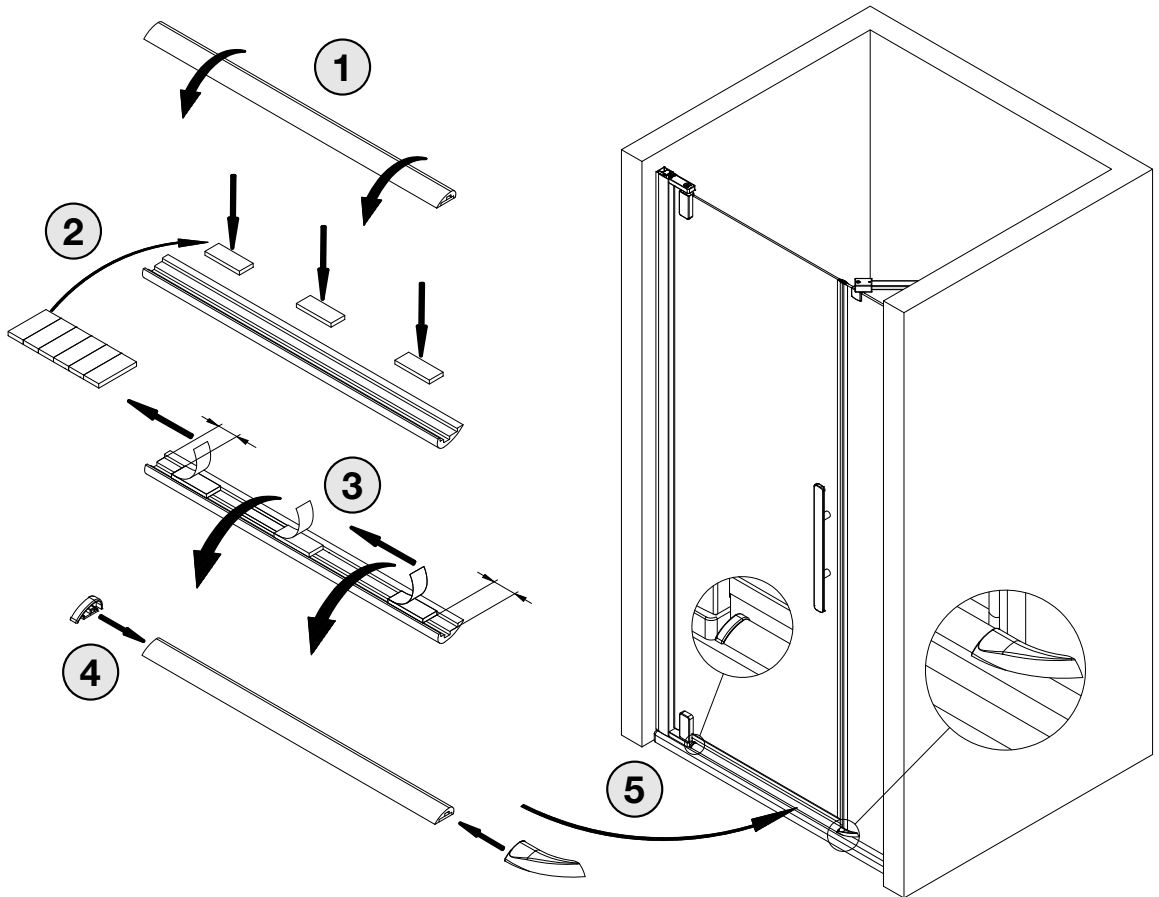

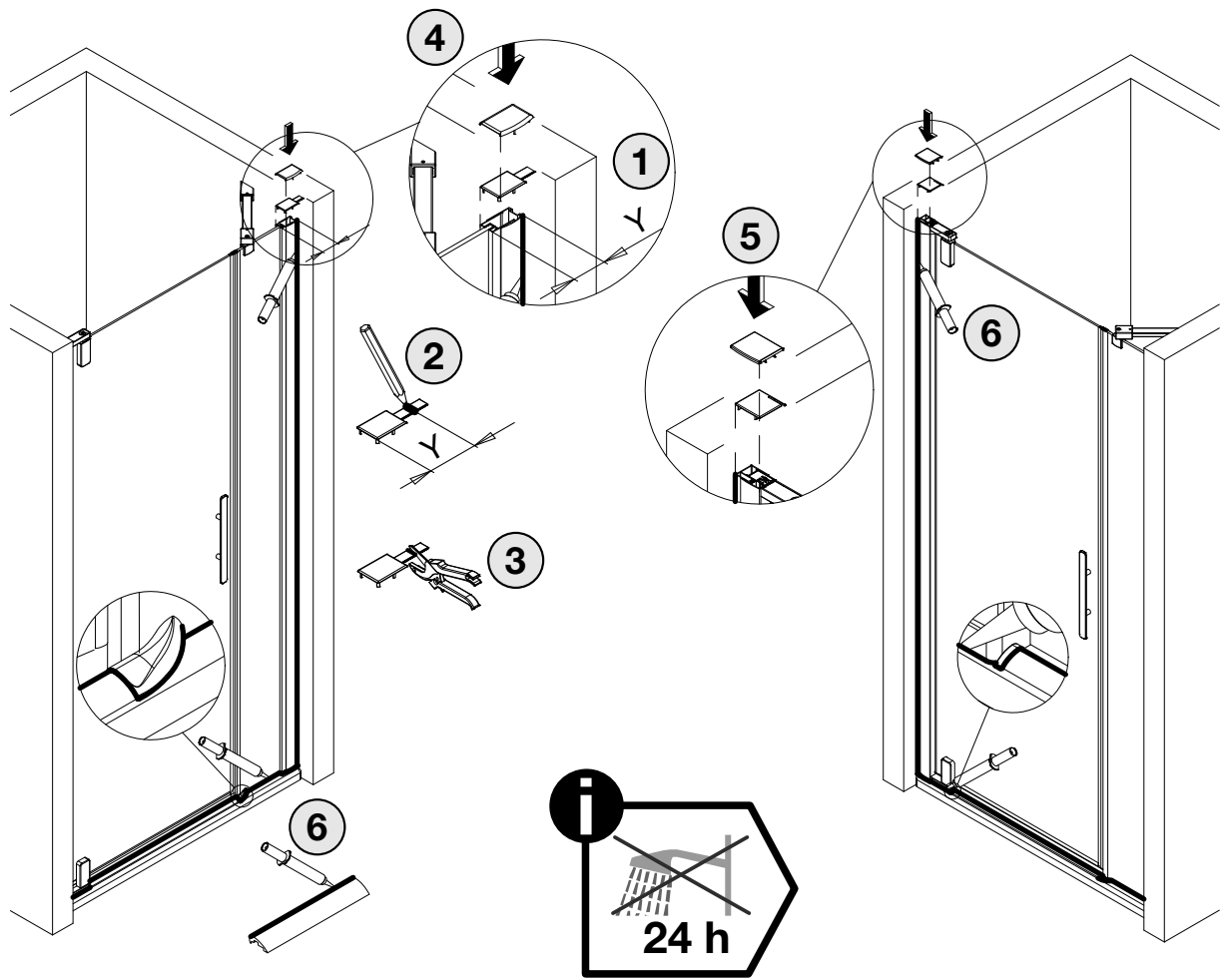

Montageanleitung Installation instructions Instructions de montage Montagehandleiding

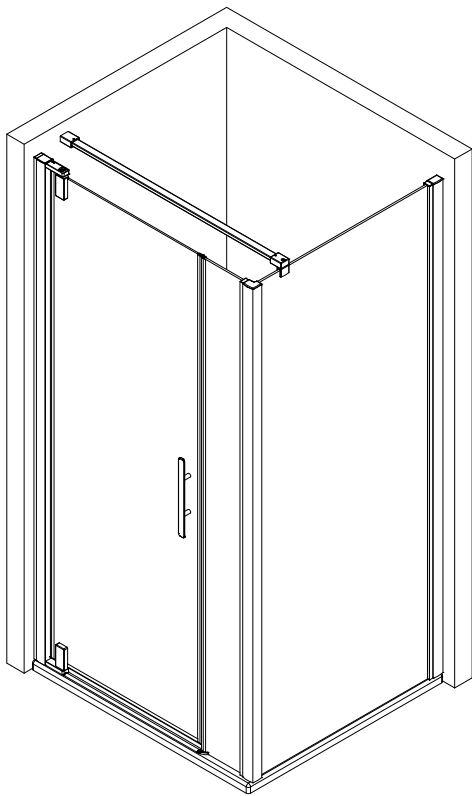

DT + FSW + SW

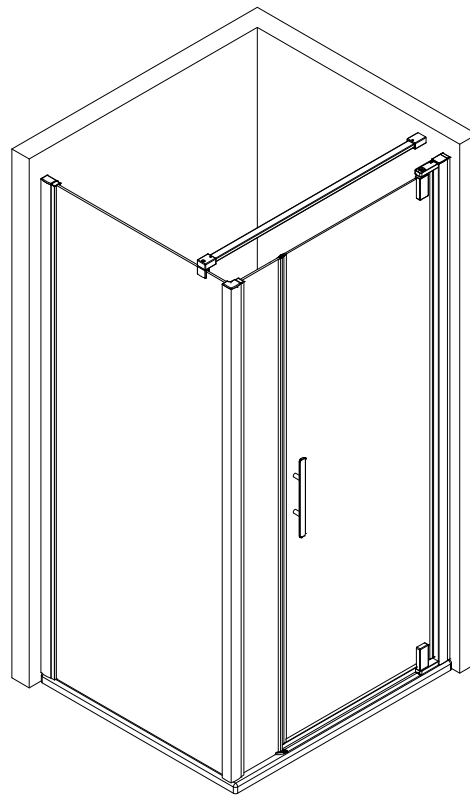

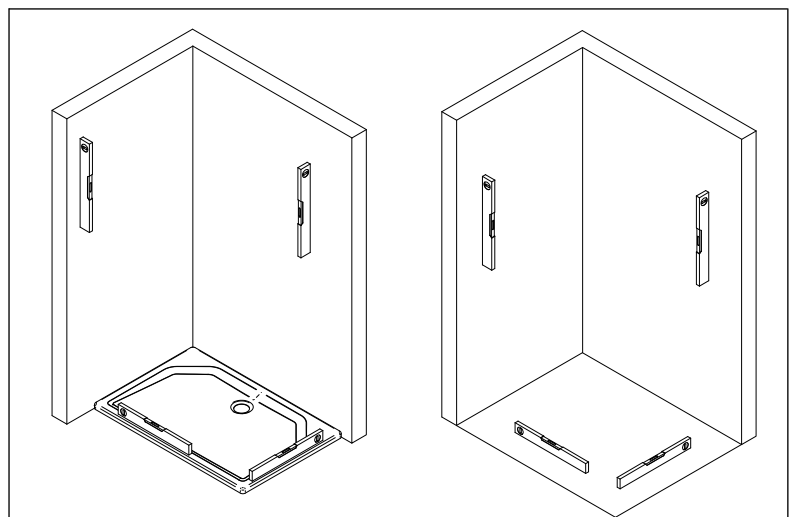
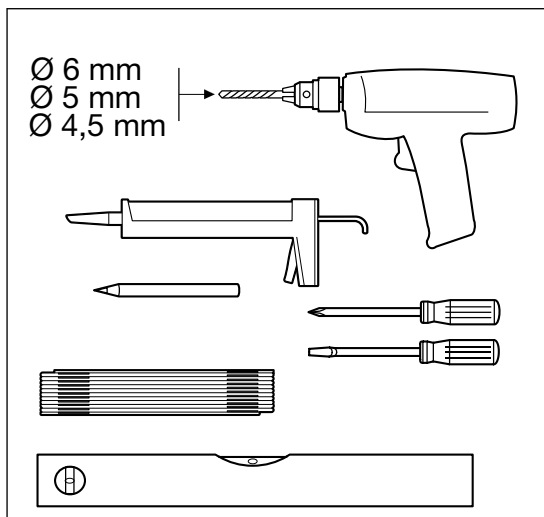
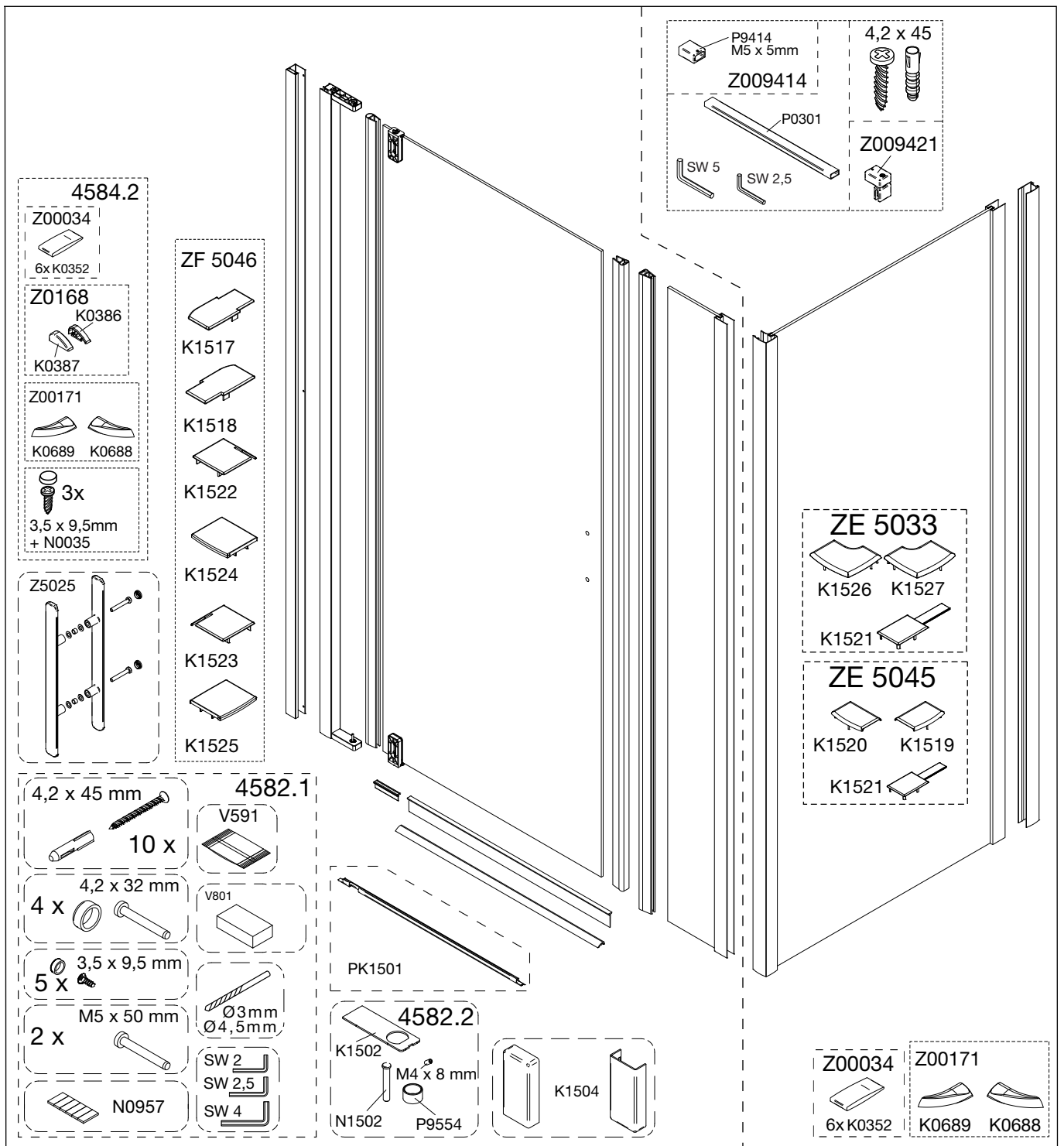

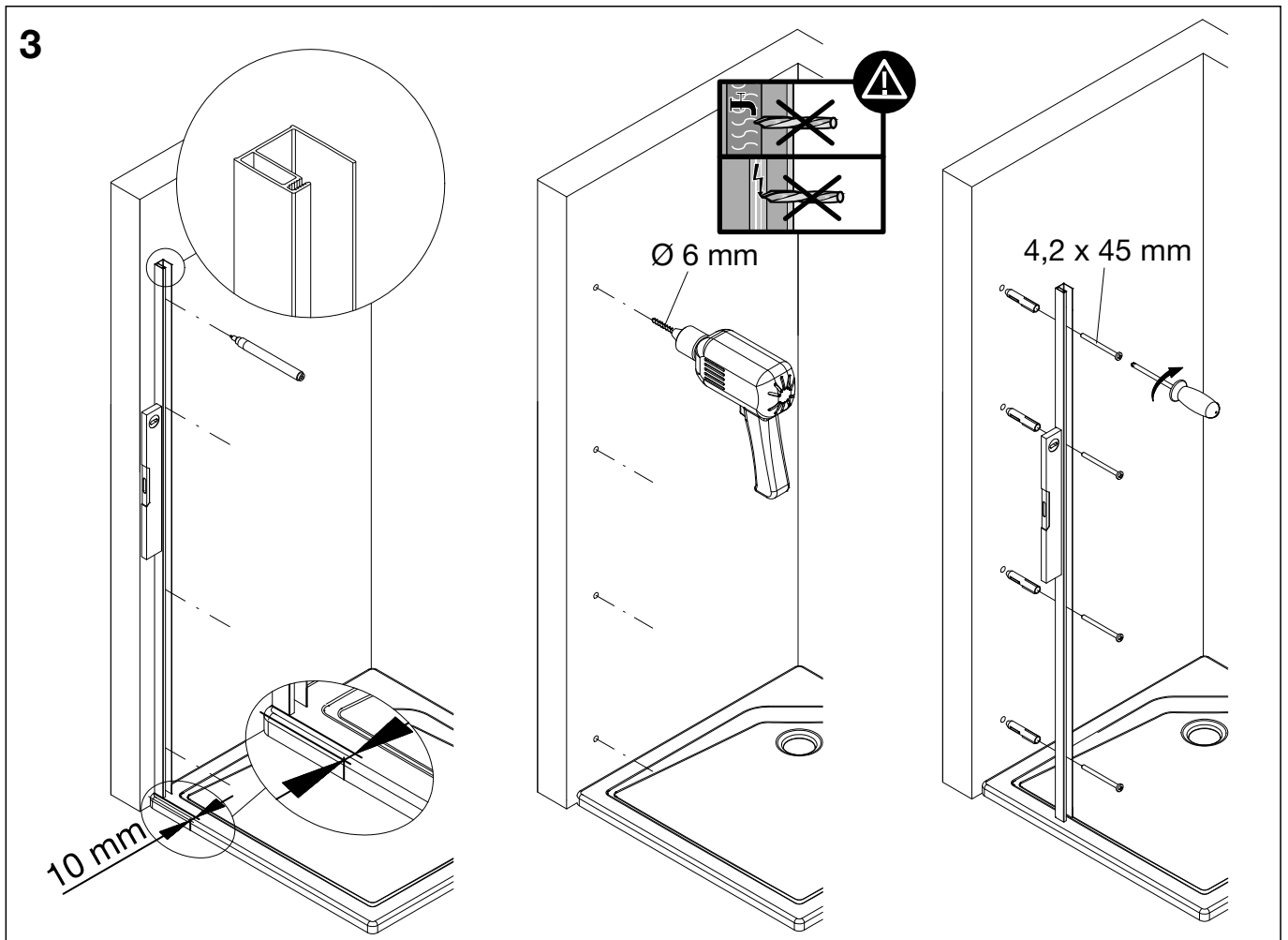
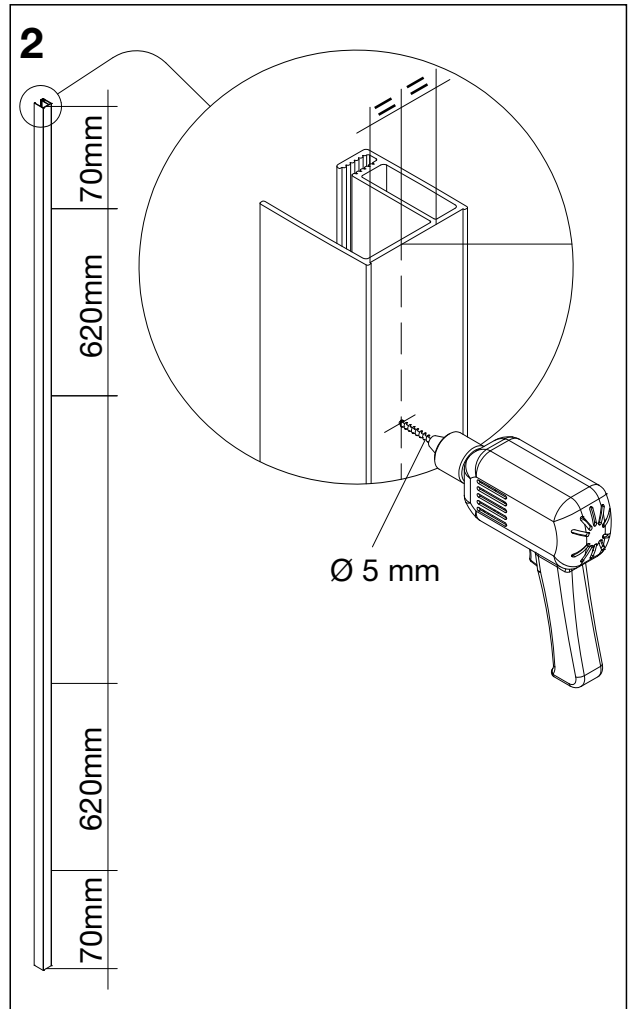
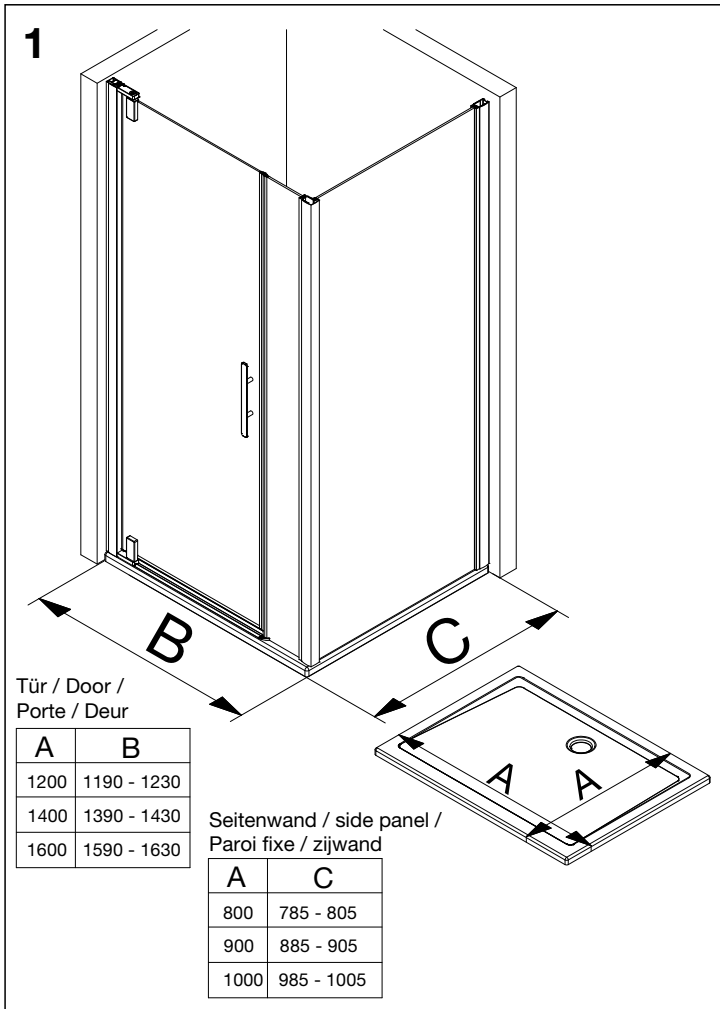

6

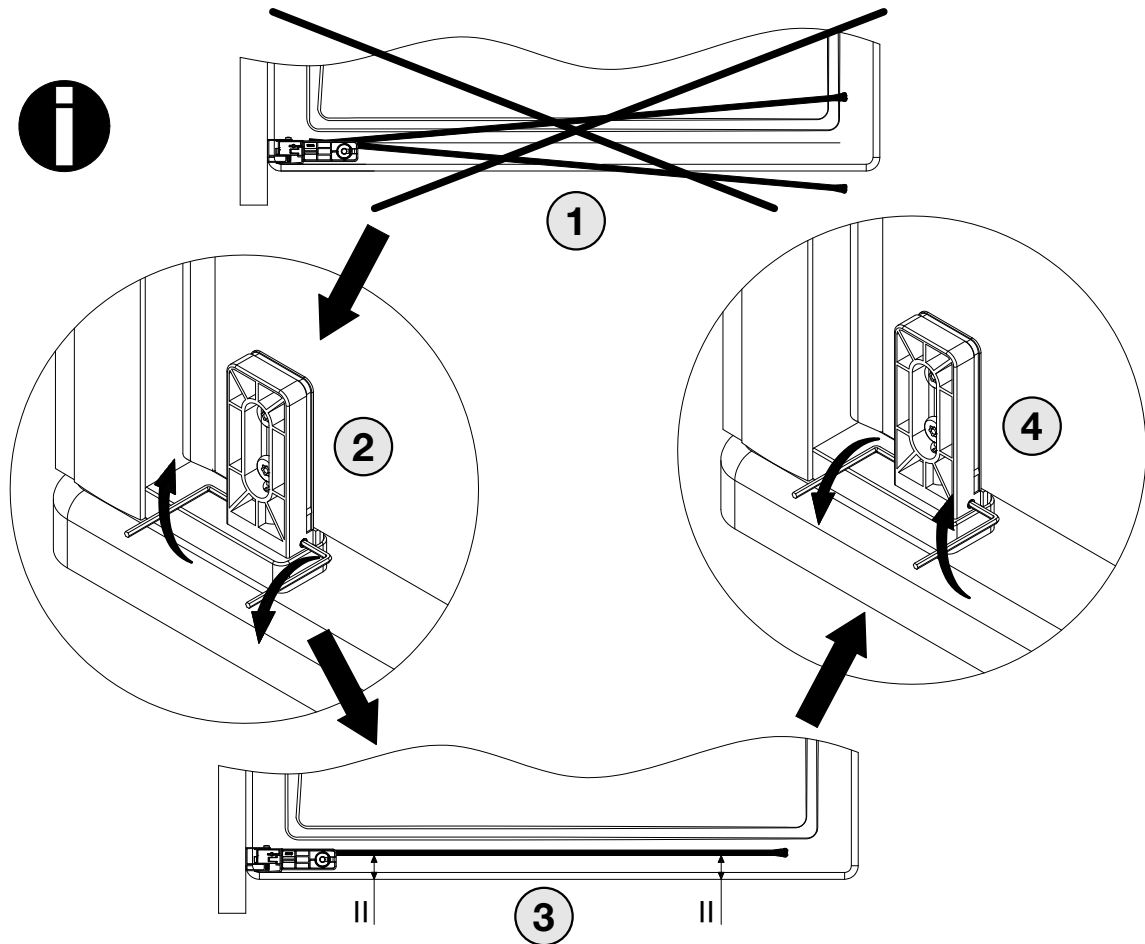

7

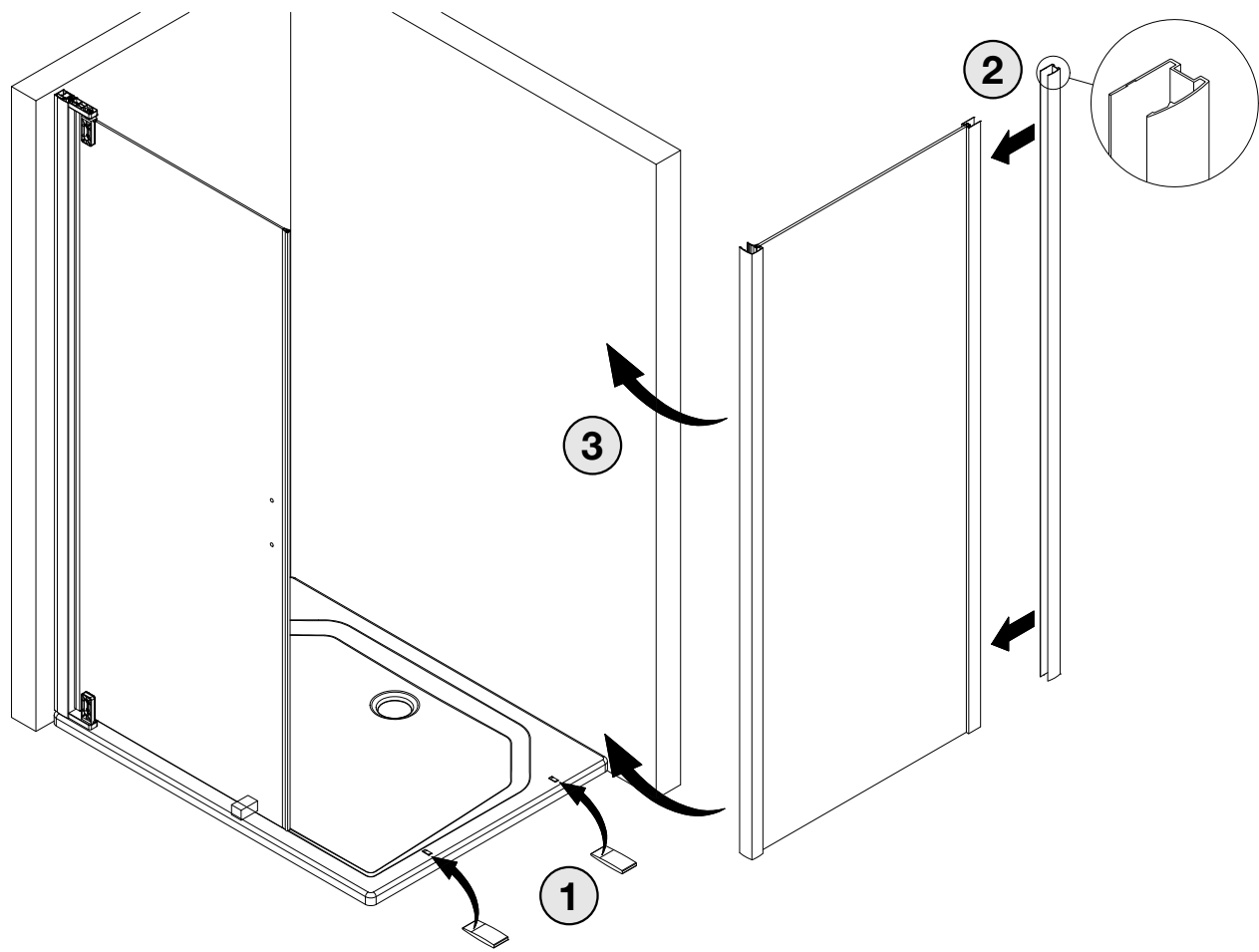

8

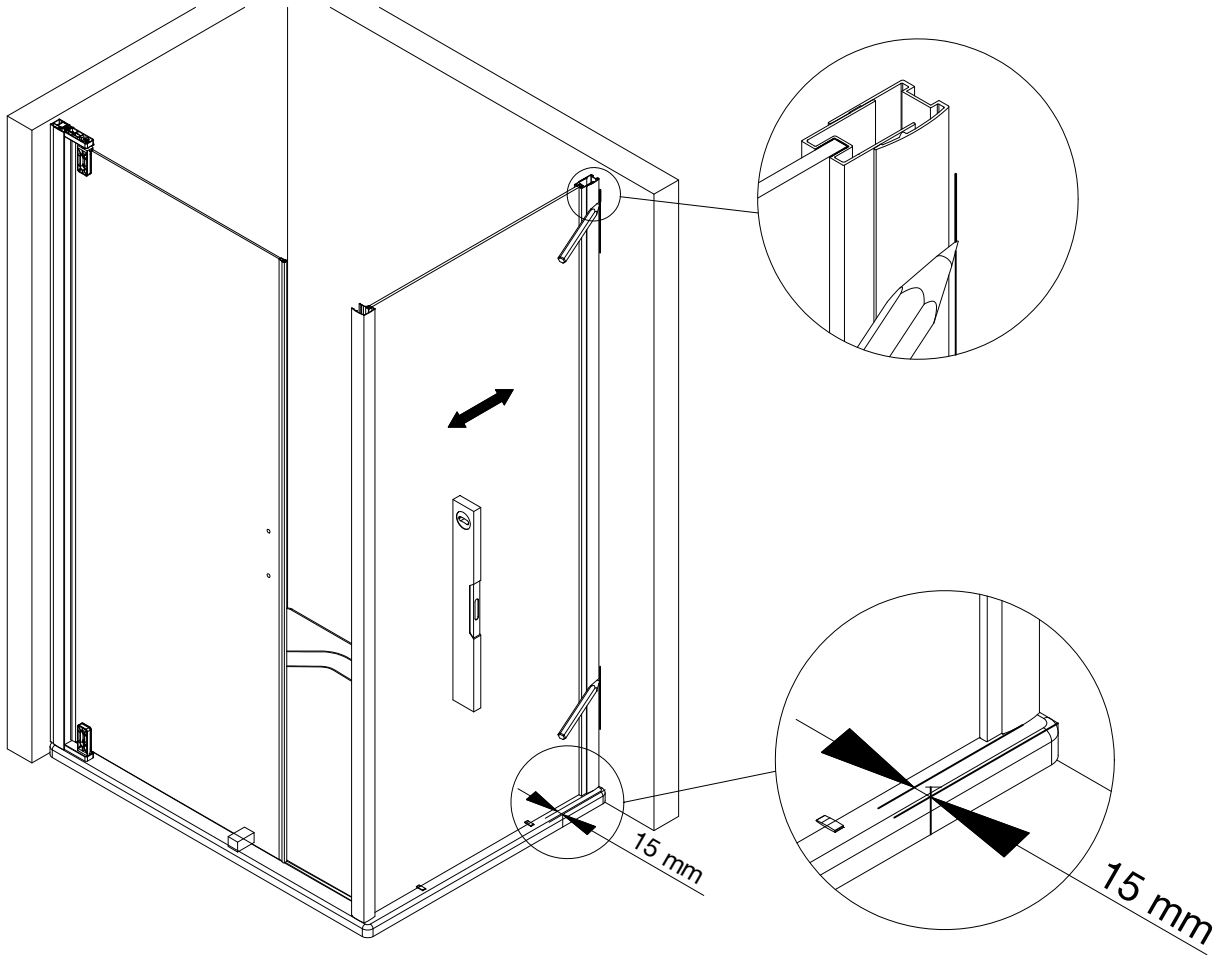

9

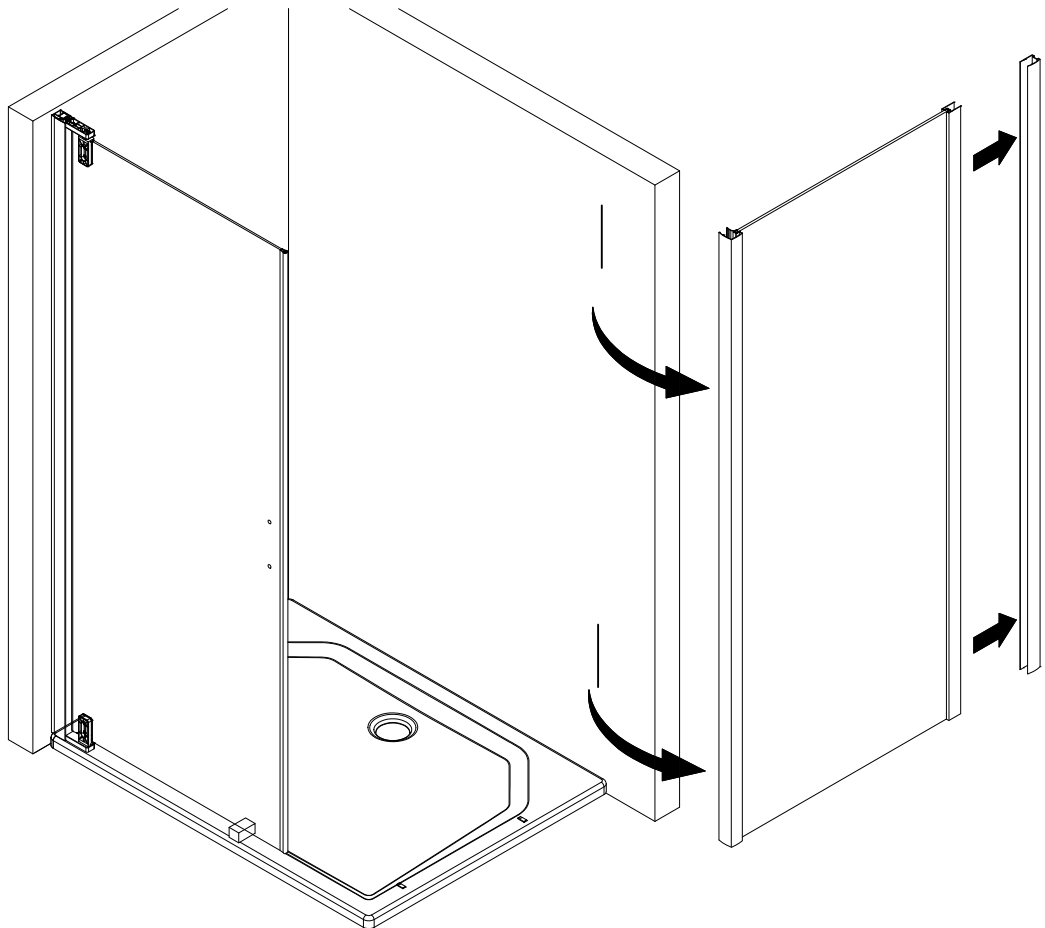

10

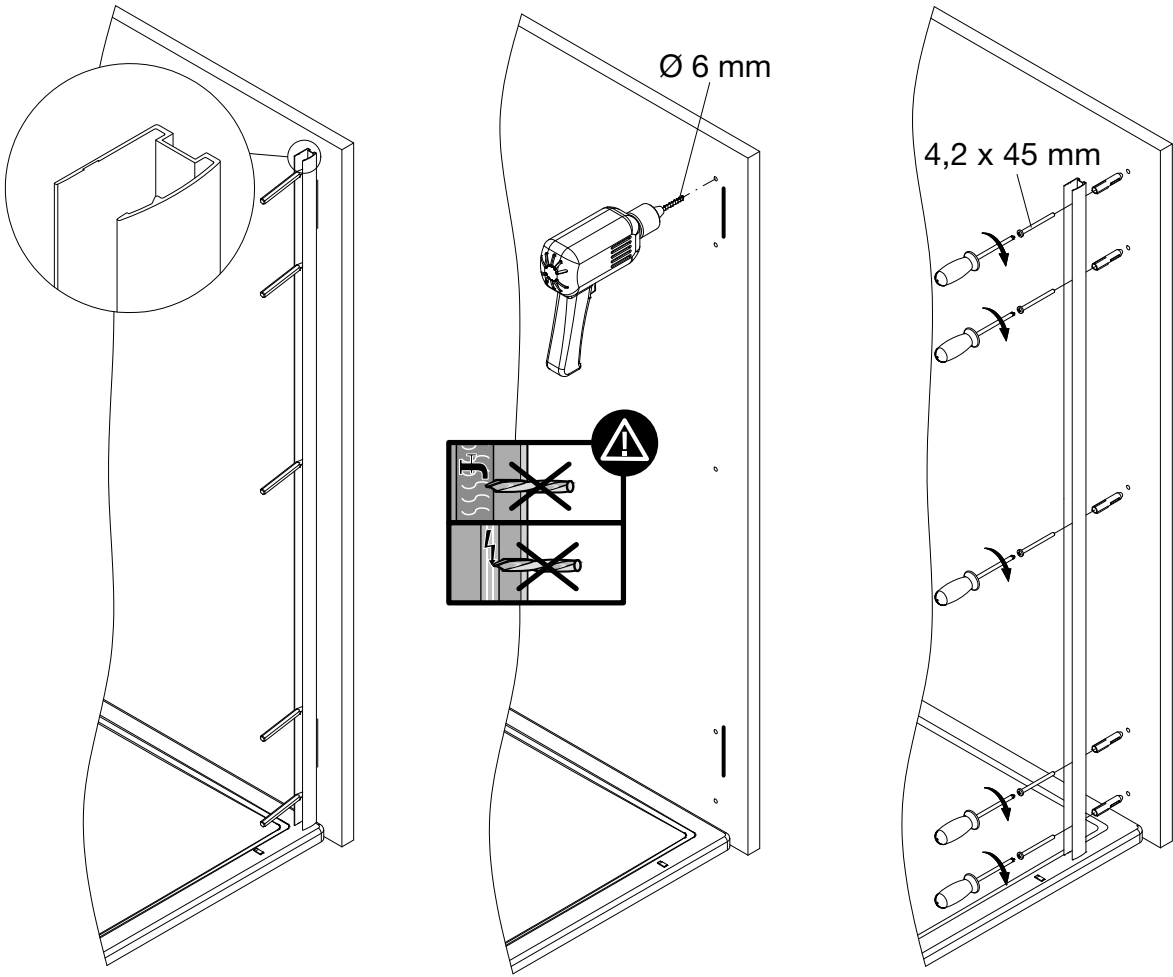

11

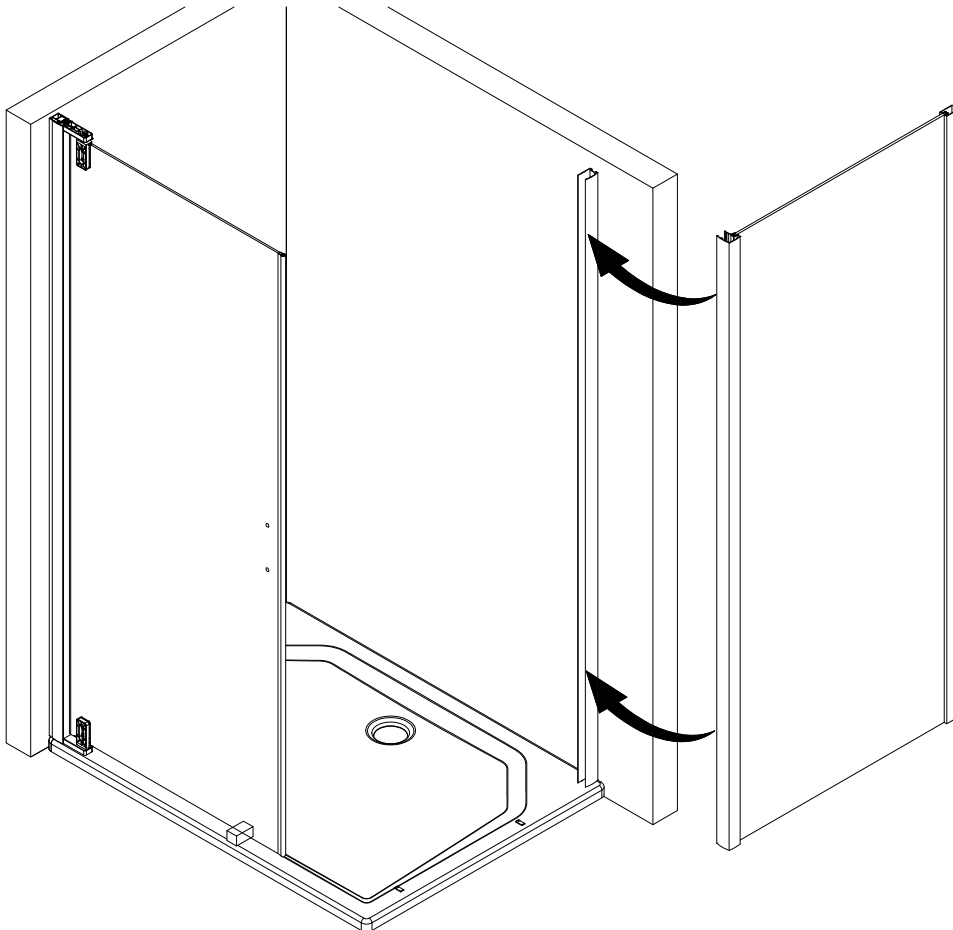

12

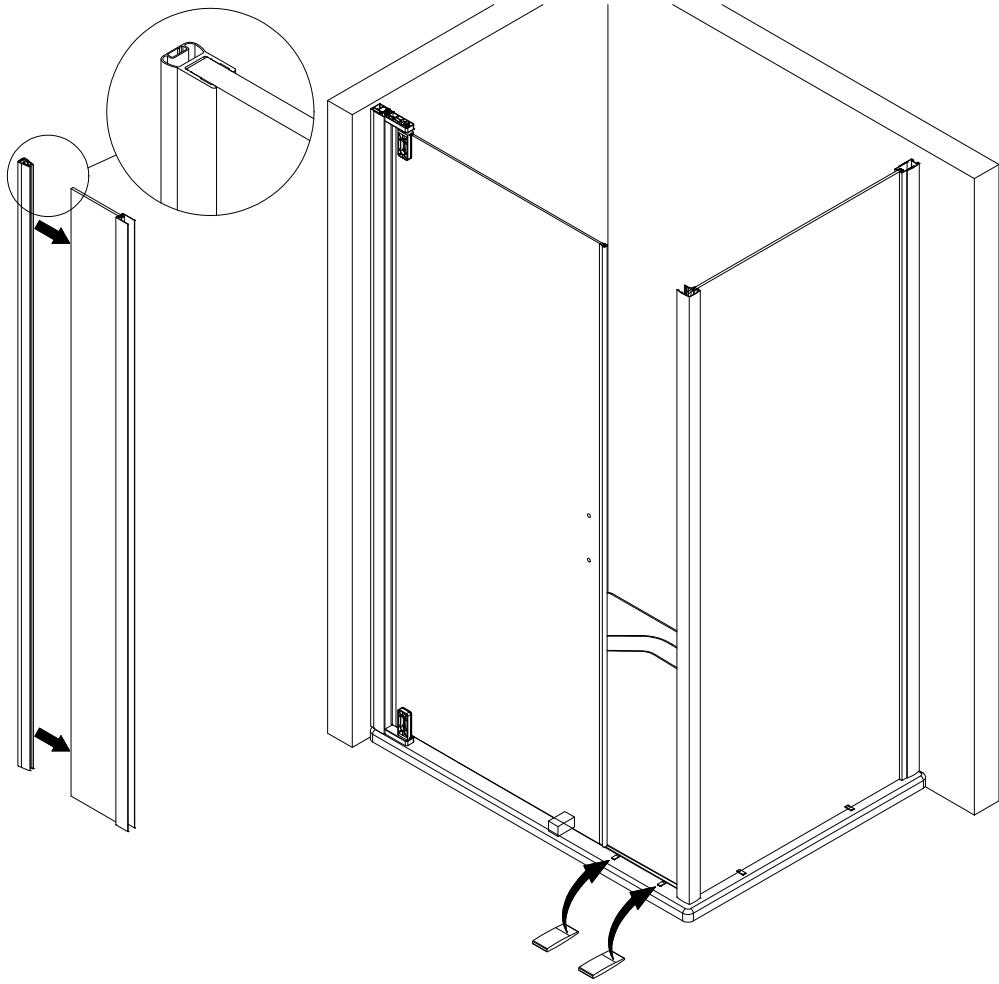

13

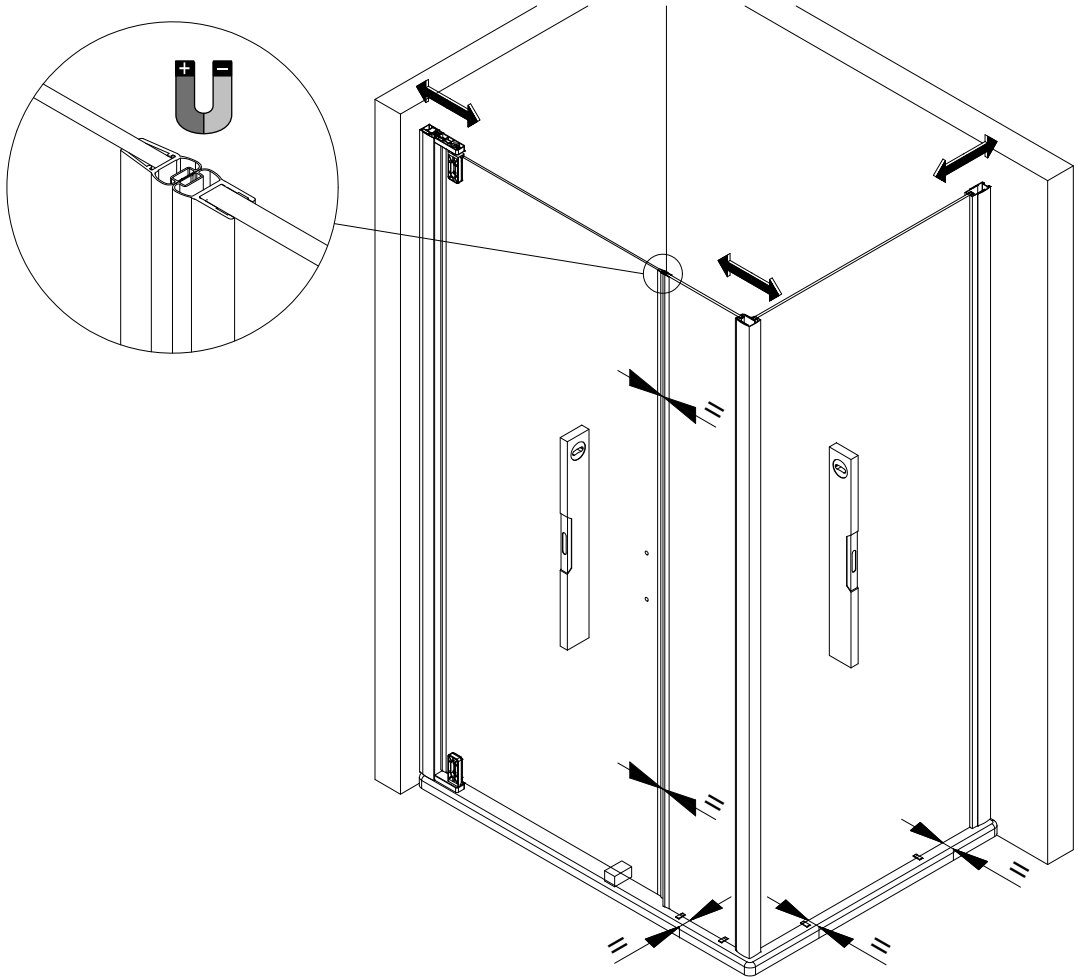

14

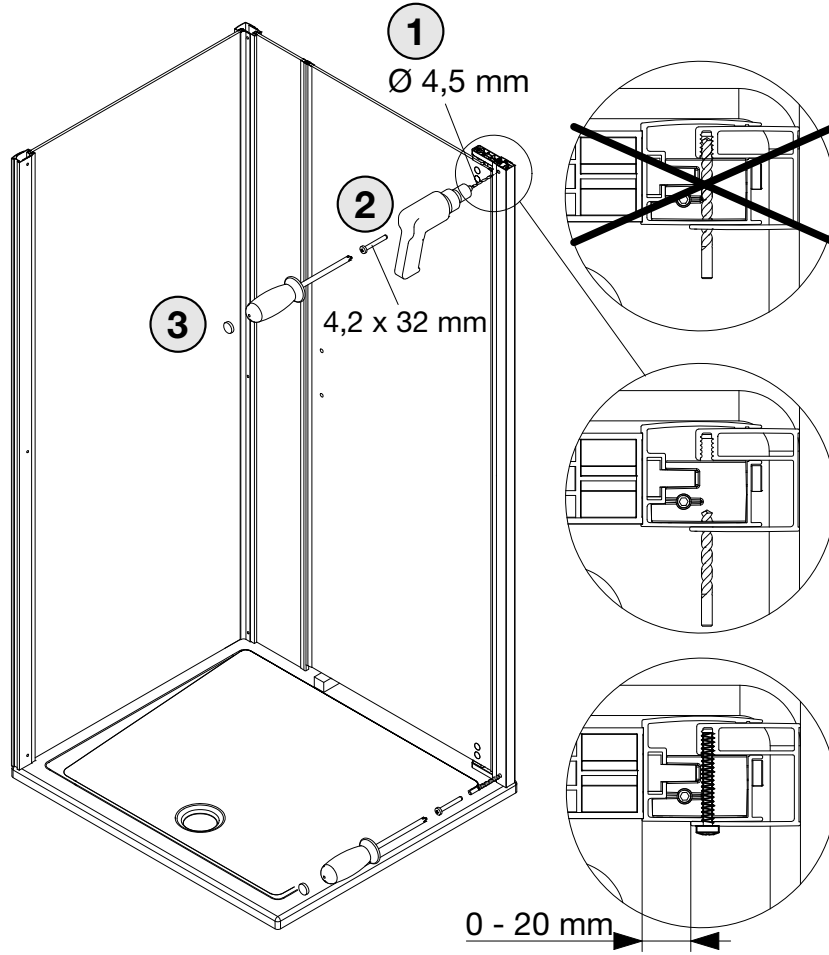

15

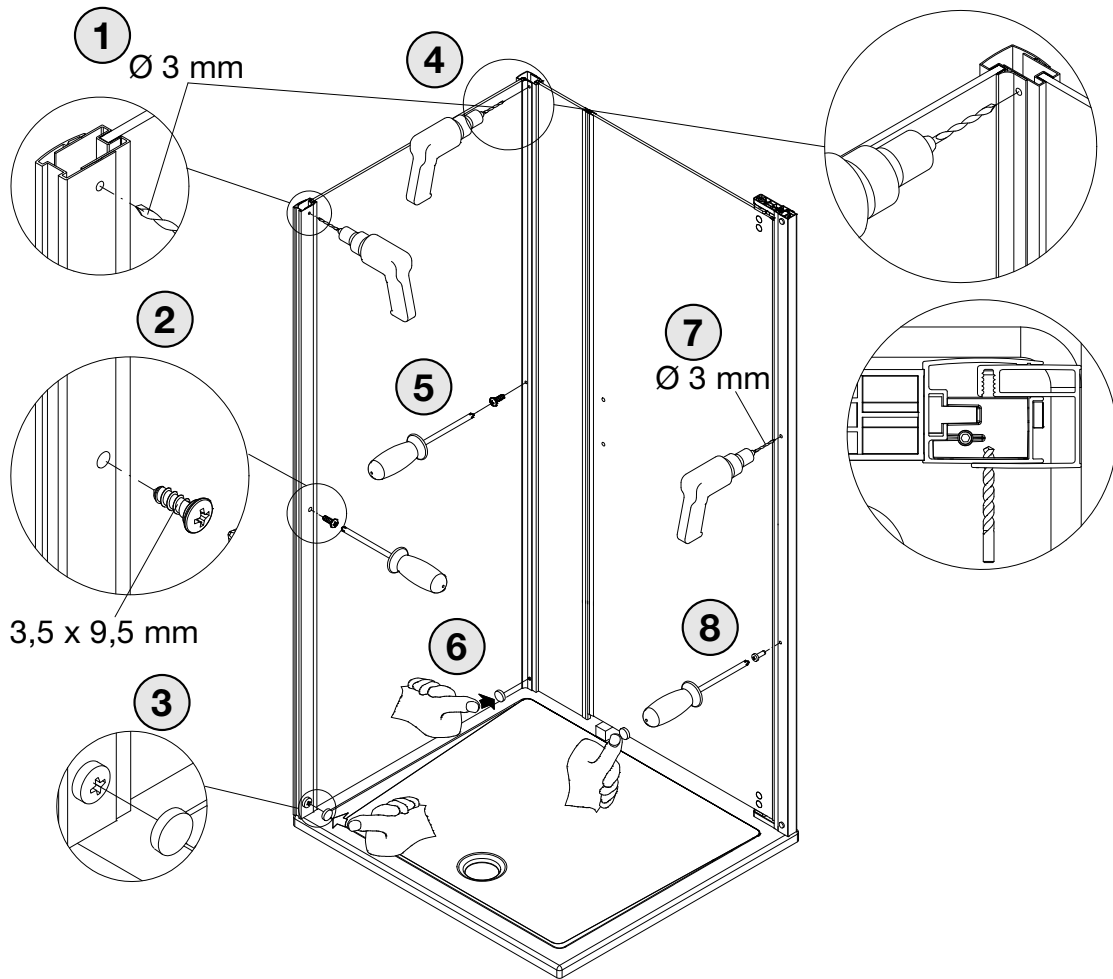

16

- Die Montage des Stabilisationsbügel entnehmen Sie dem Zusatzblatt.
- Please look into the additional sheet for the installation of the stabilizing bar.
- Veuillez regarder dans la feuille additionnelle pour l'installation de la barre de stabilisation.
- Voor de installatie van de stabilisatie stang zie aanvullende blad.

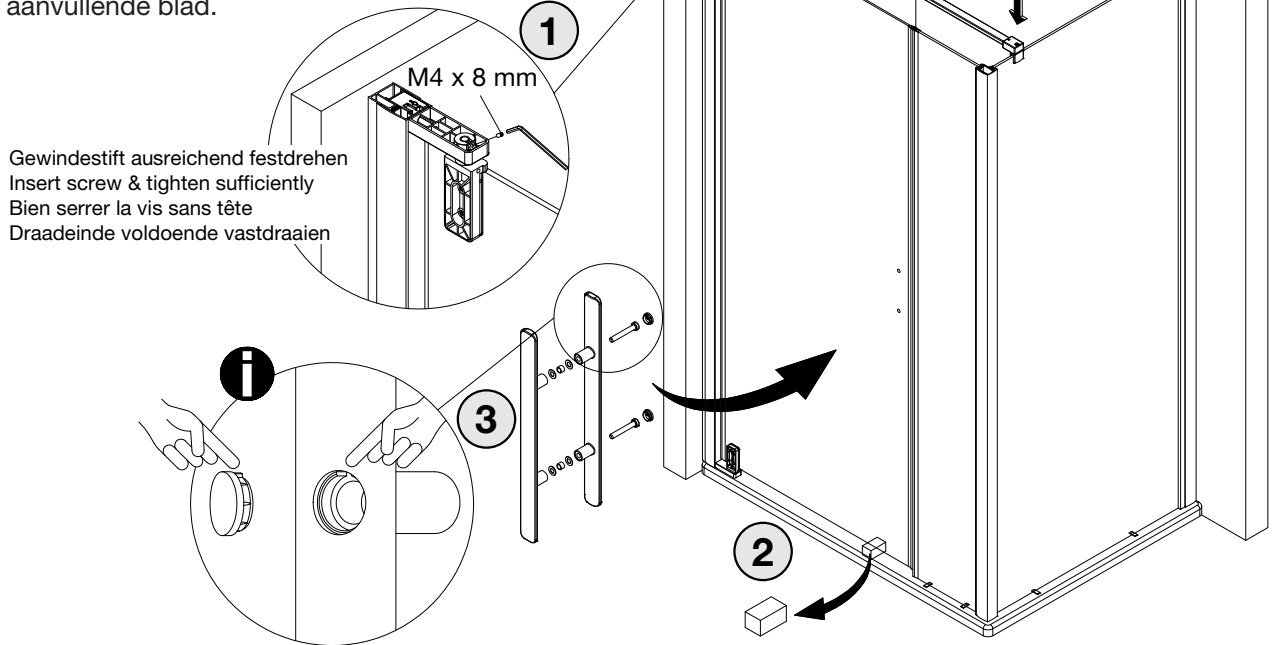

17

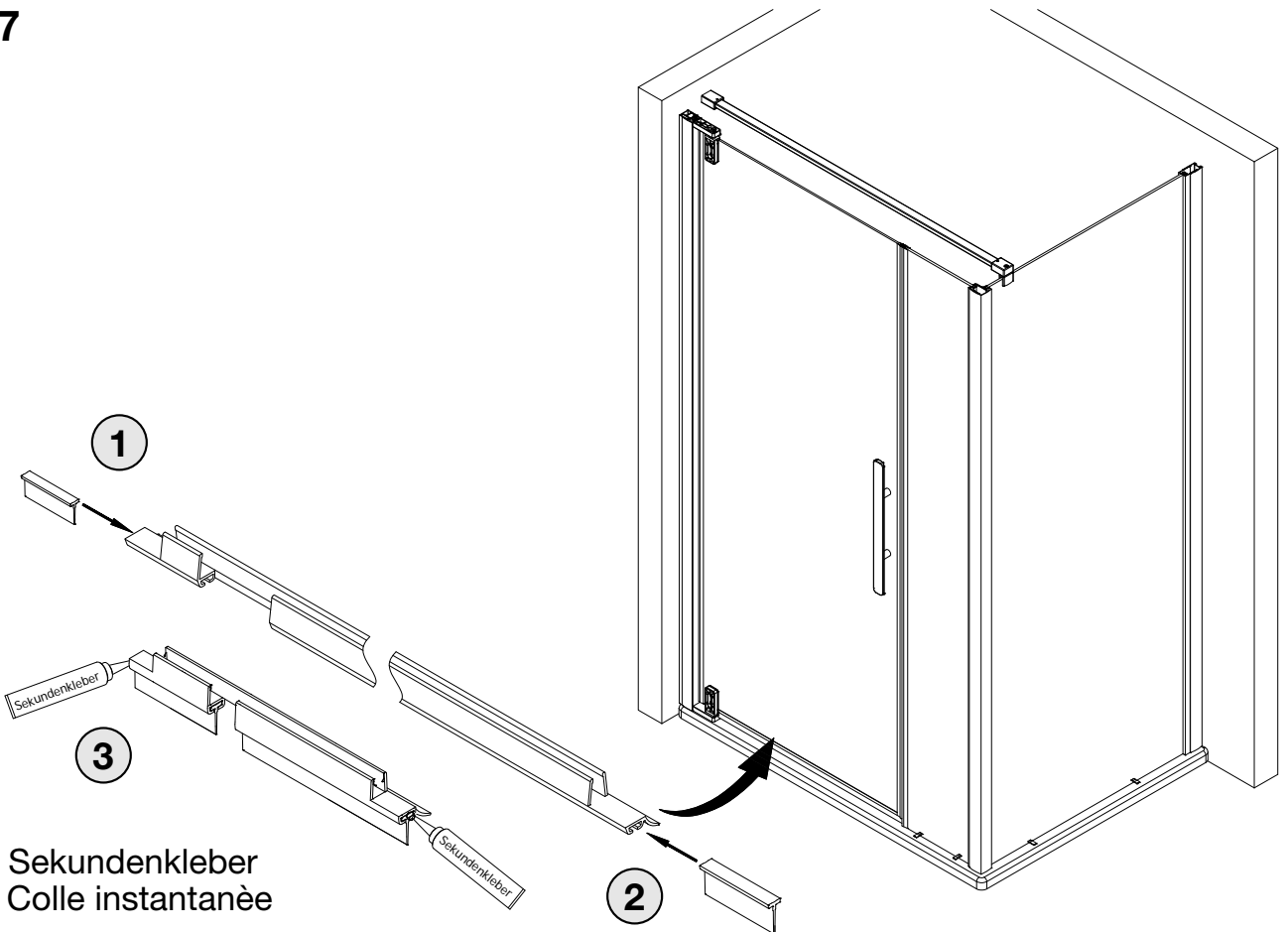

18

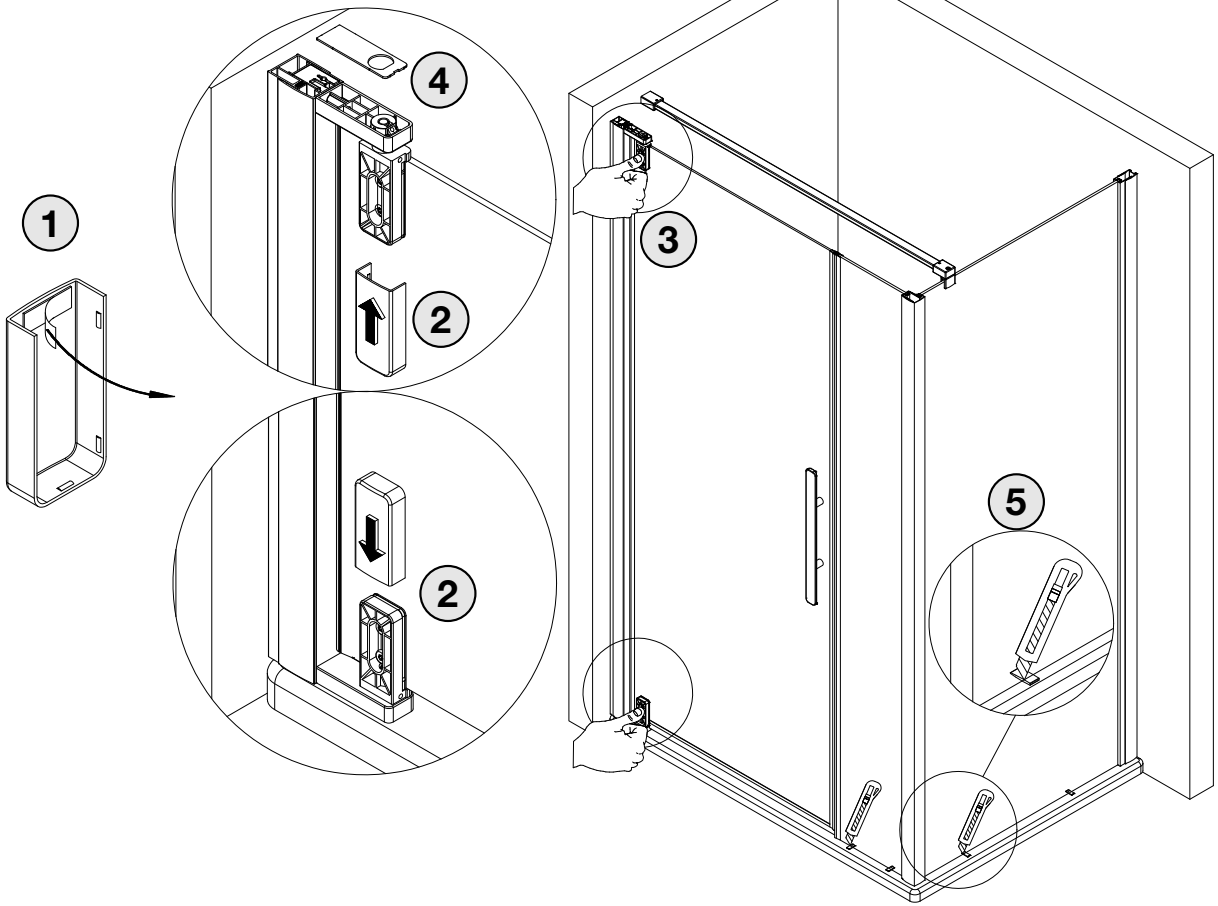

19

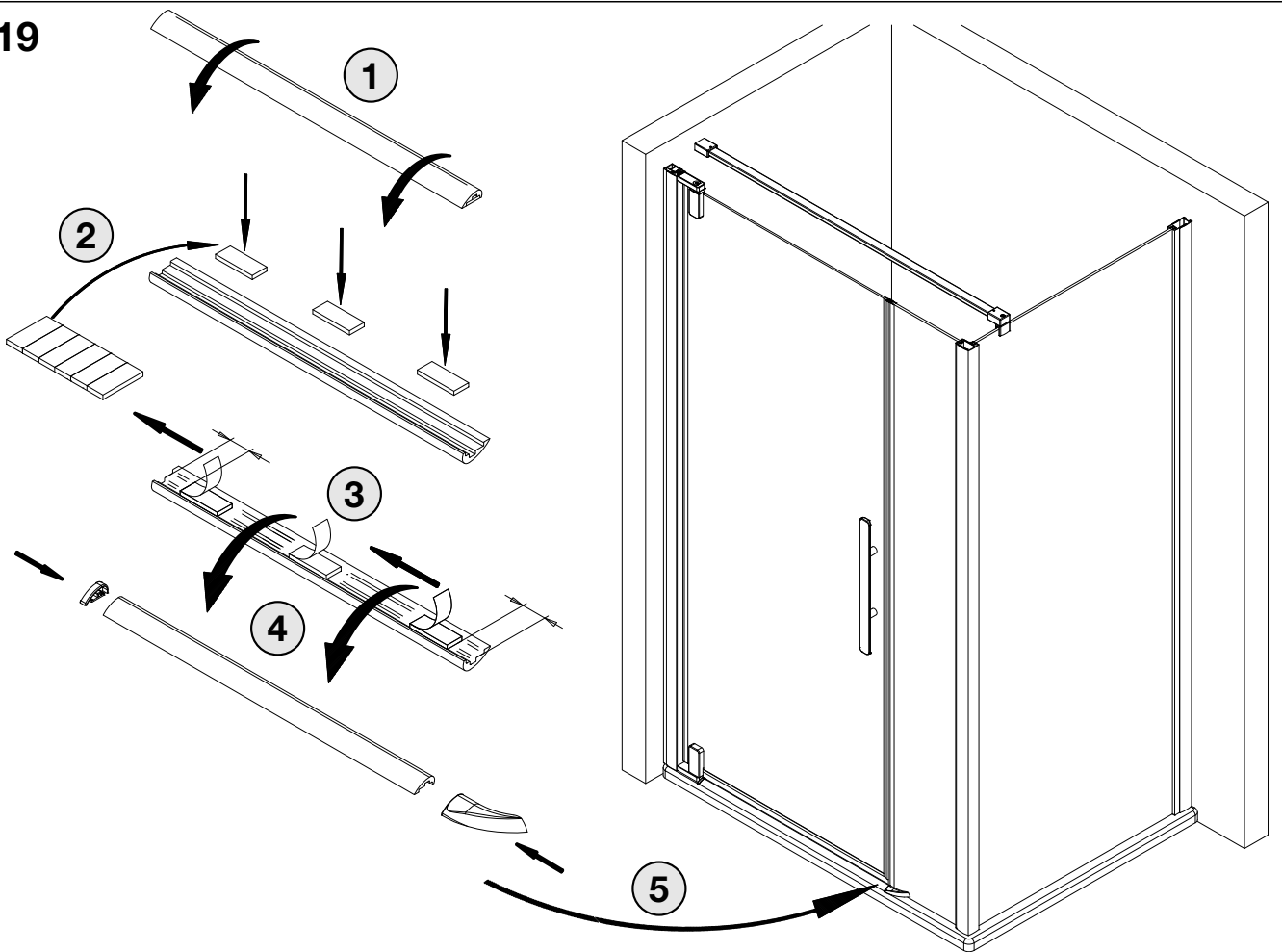

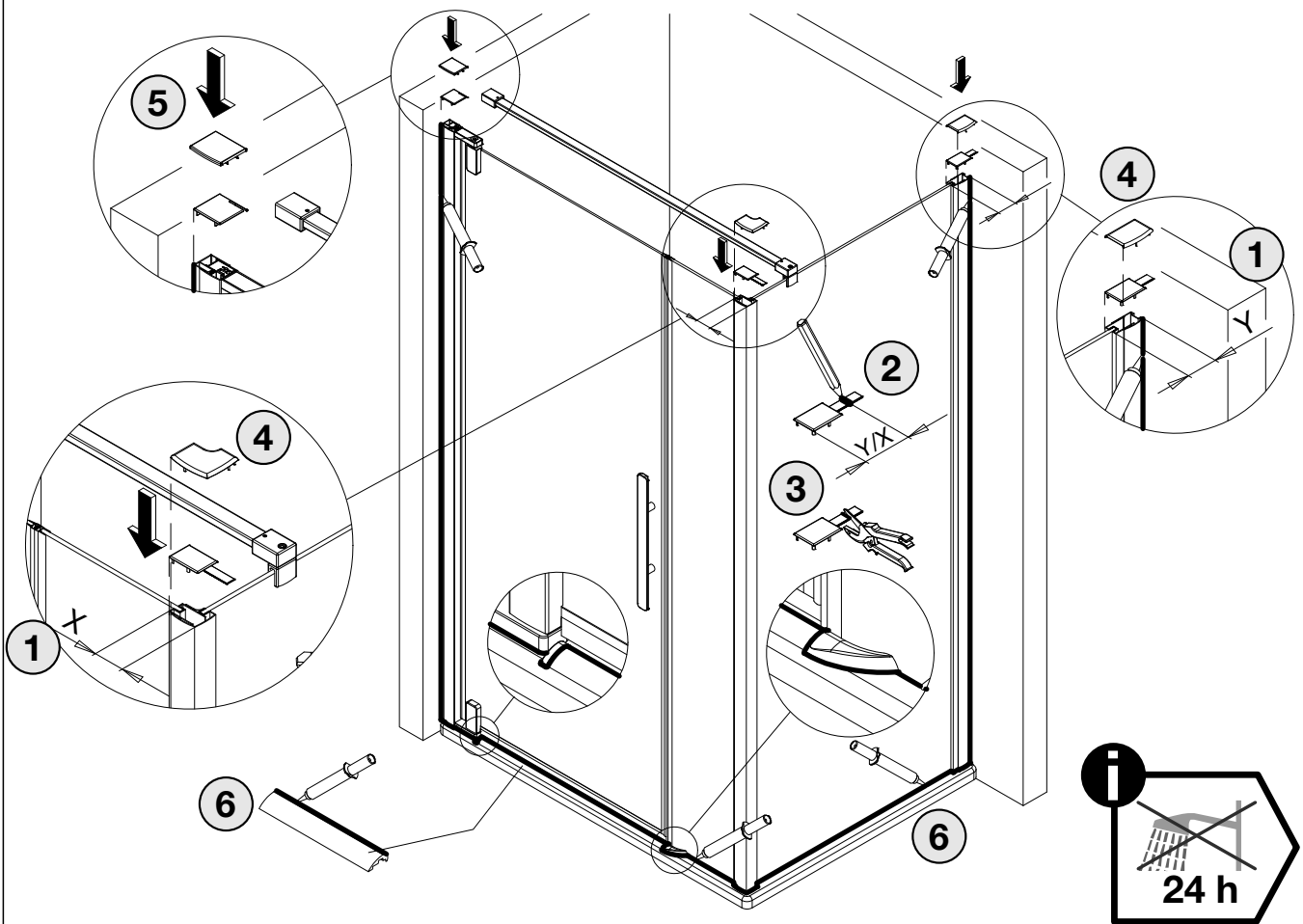

Notizen, notes

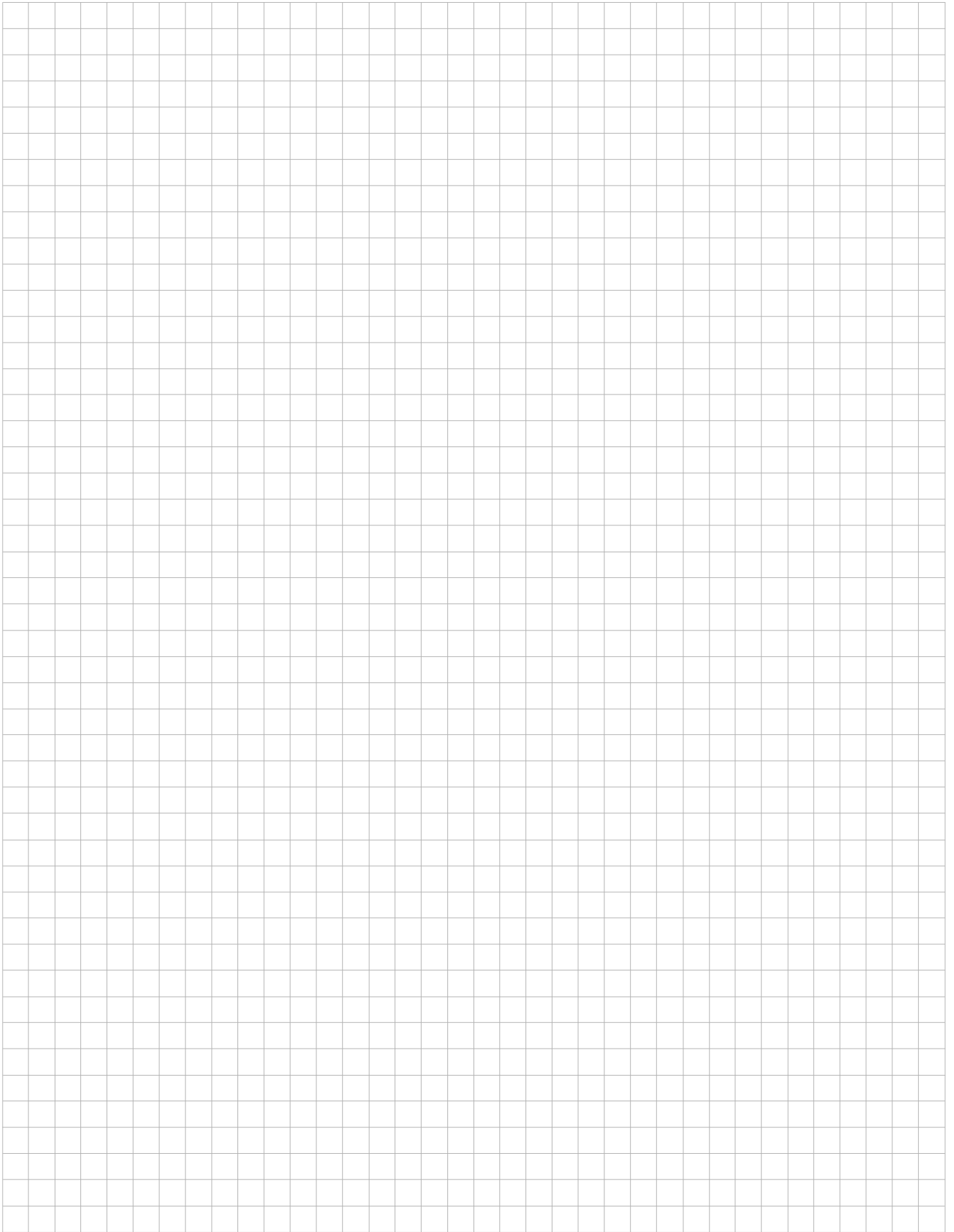

Notizen, notes

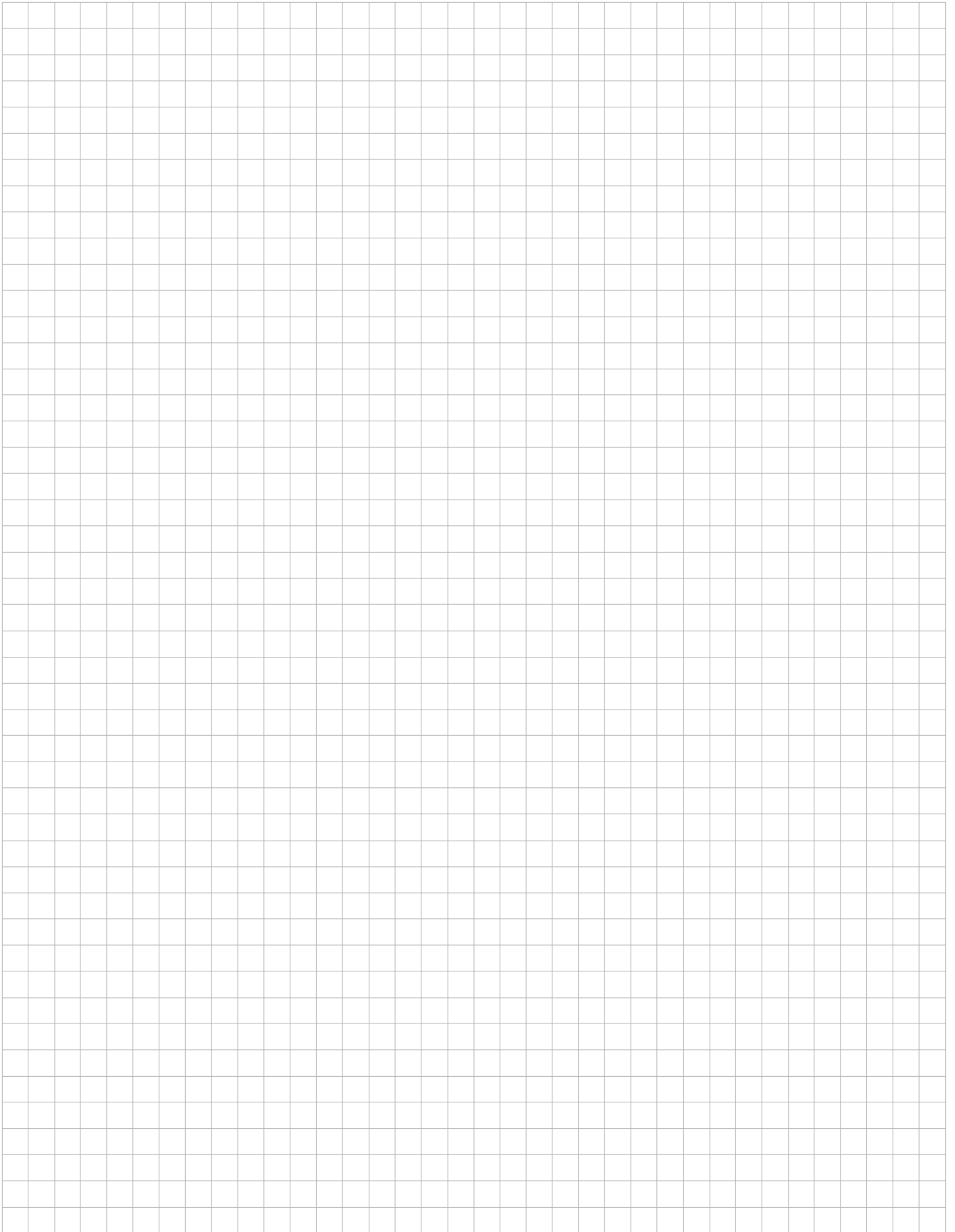

Notizen, notes

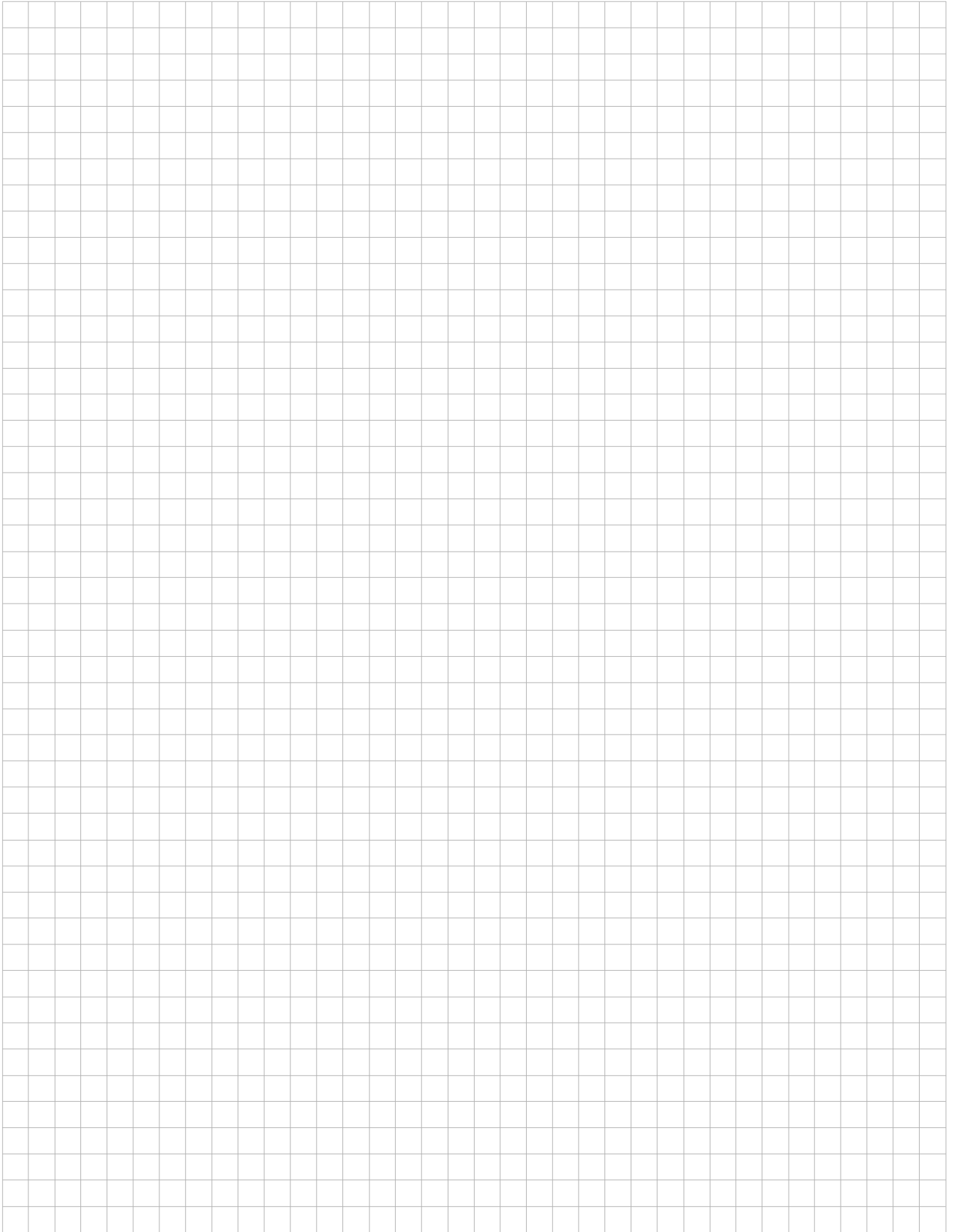

D Wichtiger Hinweis:
Duschkabinen bitte vor dem Einbau auf Transportschäden und Vollständigkeit prüfen, da Beanstandungen nach dem Aufbau nicht mehr anerkannt werden können.

GB Important information:
Please check the shower enclosure for transport damage and completeness before installation. Complaints made following installation cannot be accepted.

F Remarque importante:
avant de procéder au montage, vérifiez que le pare douche est complet et qu'il n'a pas été endommagé lors du transport. Aucune réclamation ne pourra être admise après le montage.

NL Belangrijk:
Controleer voor het inbouwen of het douchescherm bij het transport beschadigd is en of het volledig is. Na het inbouwen kunnen klachten niet meer in behandeling genomen worden.

D Sicherheitshinweis:
Einscheiben-Sicherheitsgläser nie nachträglich bearbeiten.

GB Safety information:
Single pane, safety glass panels must not be reworked in any way following supply.

F Remarques concernant la sécurité:
Vous ne devez en aucune façon tenter de retailer les vitrages en verre sécurité.

NL Veiligheidsvoorschrift:
Gehard veiligheidsglas mag niet achteraf worden bewerkt.



CE
BREUER GmbH & Co.KG Meerpfad 27 – 31 56566 Neuwied 13
EN 14428

D Duschtrennung aus einem bestimmten Scheibenmaterial

Reinigbarkeit:	Bestanden
Bruchereigenschaften:	Bestanden
Dauerhaftigkeit:	Bestanden

F Paroi de douche dans un matériau vitré particulier

Nettoyabilité:	passé avec succès
Propriétés à la cassure:	passé avec succès
Durabilité:	passé avec succès

GB Shower enclosure made of a specific plane material

Cleanability:	Passed
Fracture behaviour:	Passed
Durability:	Passed

NL Douche-afscheiding van bepaald ruitmateriaal

Reinigbaarheid:	Doorstaan
Bruekeigenschappen:	Doorstaan
Duurzaamheid:	Doorstaan

Dusch-Info
Meerpfad 27-31
D-56566 Neuwied
Tel: 02631-8607-0

