

Utronic

Mounting instructions Infrared Sensor Urinal
优楚尼克 安装说明 红外线感应小便器

0830370092

Index

English	中文
Technical information	技术信息
Assembly dimensions..... 3	安装尺寸 3
Before you start 4	您开始安装前..... 4
Check valves 5	单向阀..... 5
Mounting instructions	安装说明
Infrared Sensor Urinal 6	红外线感应小便器 6
Servicing instructions	使用说明
Battery replacement 8	更换电池 8
Replace the solenoid valve 9	更换电磁阀 9
Replace the electronic unit11	更换电子元件.....11
Cleaning the dirt trap..... 12	清理存水弯 12
Trouble shooting guide	可能发生的故障及解决办法
Removing errors 13	解决办法 14

We reserve the right to make technical improvements and enhance the appearance of the products shown.
由于技术改进, 我们保留改变产品规格说明的权利。

Position of fixing points and water supply

固定位置和供水

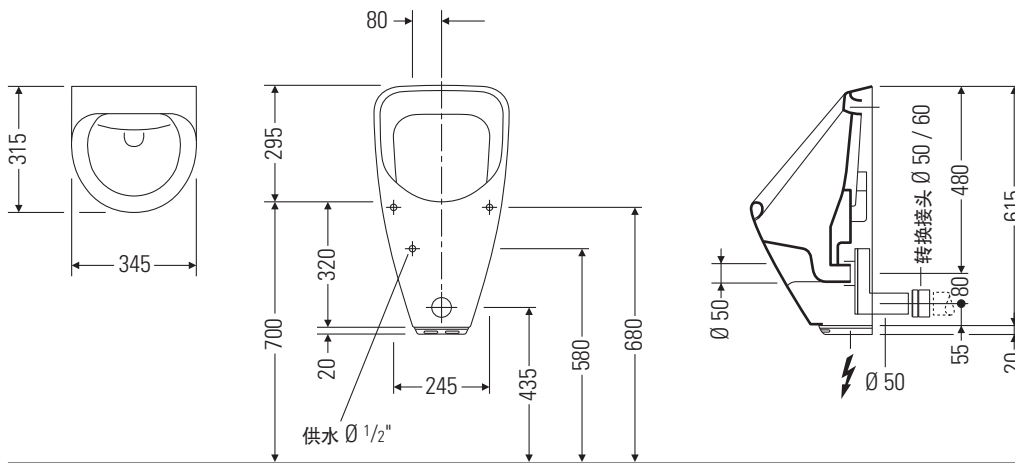
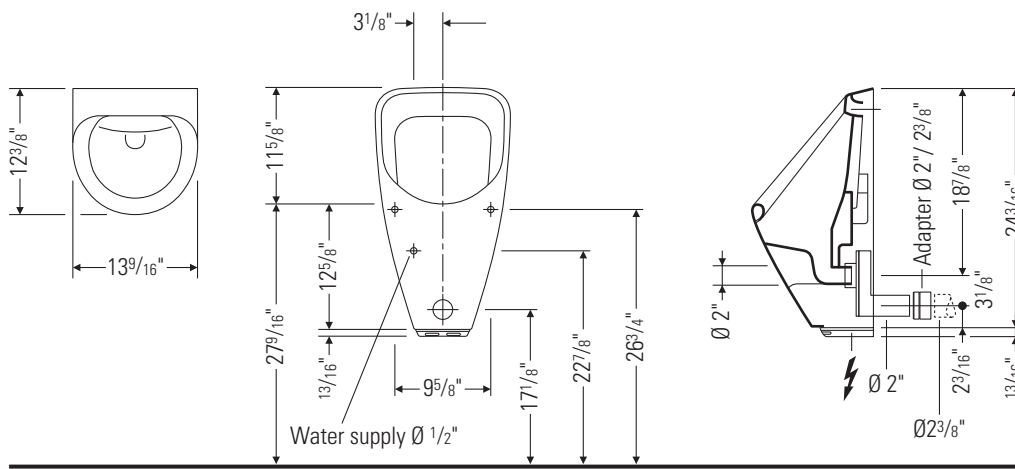

BEFORE YOU START:

Please take a few minutes to read the following installation instructions. Your new urinal is a low consumption water urinal (0.5 gpf / 1.9 lpf).

For a safe and efficient operation of the urinal a water pressure between minimum 25 psi (175kPa) and maximum 80 psi (550kPa) must be respected. When installed in accordance with these restrictions it meets the performance requirements of ASME Specification A 112.19.2-2003.

您开始安装前:

开始安装前, 请您花几分钟时间阅读以下安装说明书。您所购买的小便器是一种低耗水量的小便器 (0.5 gpf / 1.9 lpf)。

为了保证小便器的安全及有效的操作, 进水压力必须控制在最低为25磅/平方英寸 (175kPa)与最高为80磅/平方英寸 (550kPa)之间。当满足以上所述的要求时, 产品的性能将达到ASME A 112.19.2-2003的要求。

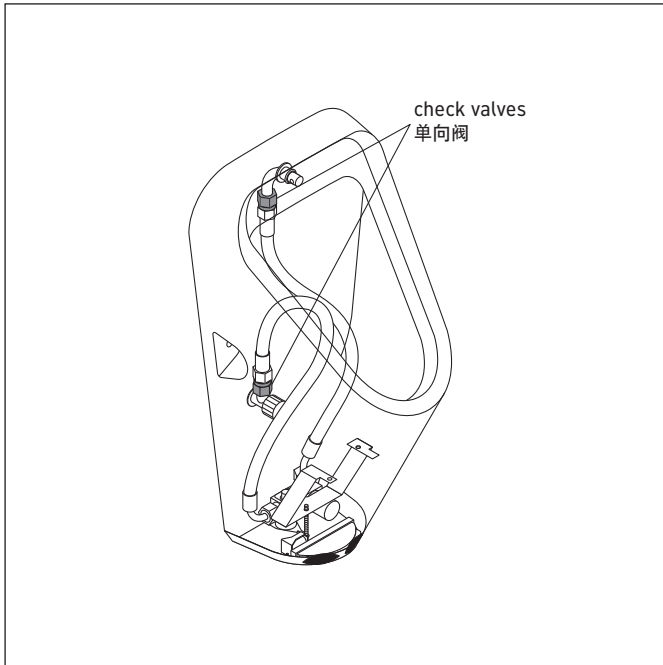

CHECK VALVES

This unit is equipped with two spring loaded check valves (one-way valves) to prevent a back water flow into the supply line. Refer to drawing left for location of the valves.

单向阀

本款小便器配备两个弹簧式单向阀，用以防止水逆流回供水管。单向阀的位置，请查看左图。

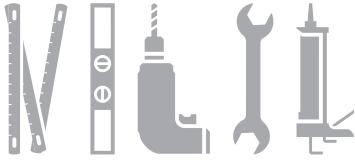

Mounting of the urinal

小便器的安装

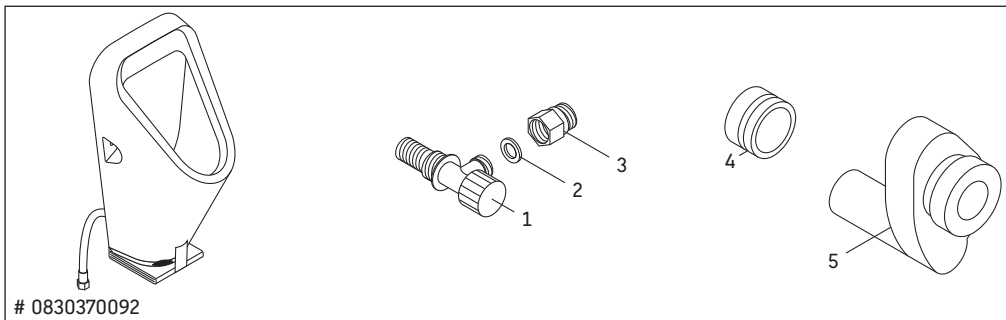

0830370092

Electronic Urinal (Utronic)

Angle stop (1), washer (2) and check valve (3).

Adapter (4), siphon (5), horizontal outlet.

电子感应小便器 (优楚尼克)

角阀 (1), 垫圈 (2) 和单向阀 (3)

转换接头 (4), 横出水虹吸管 (5)

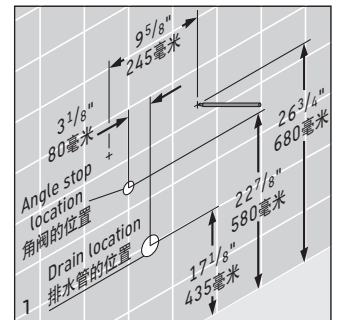

Measure and mark distance of the fixing points, the angle stop and outlet from the finished wall.

按图示尺寸在完成的墙面上标出固定孔、角阀和排水孔的位置。

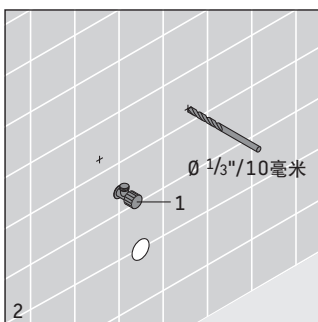

Drill two holes 1/3" (10 mm) diameter (for exact location of the holes see diagram on the page 3 or page 6 picture 4).

钻两个直径为1/3" (10毫米) 的孔 (具体位置请参见第3页的图表或第6页第4幅图)。

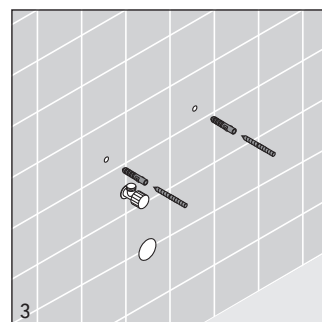

Alternately tighten screws until urinal is firmly fixed to the wall.

交替紧固螺杆, 以便小便器能稳固地安装在墙上。

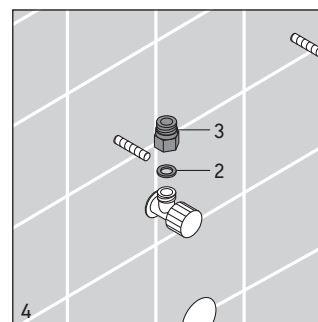

Add washer (2) and check valve (3) to the angle stop.

将垫圈 (2) 和单向阀接到角阀 (3) 上面。

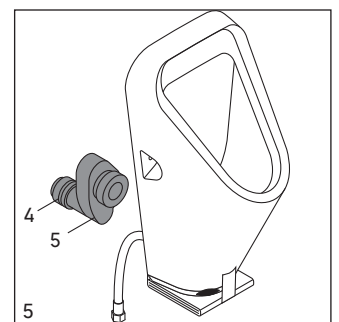

Glue adapter (4) to the siphon's pipe (5) and attach this unit to the urinal outlet.

将转换接头 (4) 涂上胶水接到虹吸管的排水管 (5) 上。并连接到小便器的排水口上。

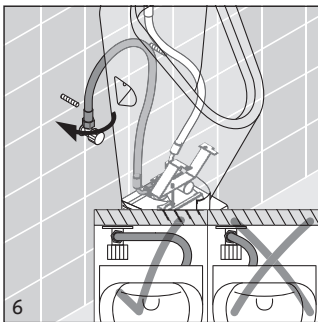

Attach flexible pressure hose to the angle stop.

将耐压软管接上角阀。

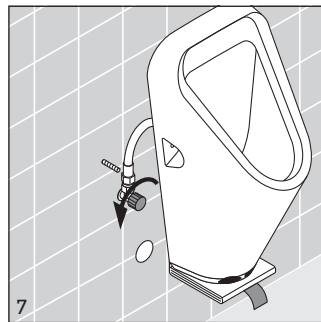

Open the angle stop counterclockwise (3 turns).

逆时针方向打开角阀（3圈）

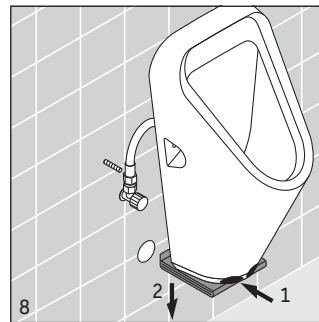

Remove the tape on the electric cover protector.

拉掉金属罩护盖上的胶带。

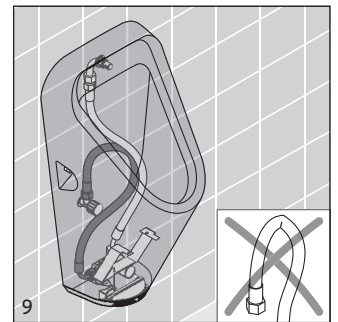

Push down to remove electric cover protector and push forward so siphon fits into the drain hole.

向下按，卸下金属罩的护盖，再向前推使虹吸管插入排水孔。

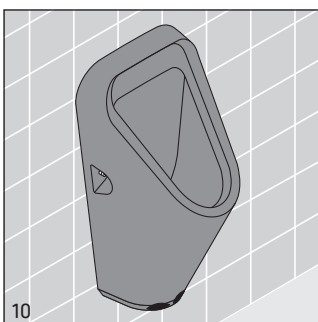

Put the urinal on the screws.

把小便器挂在螺杆上。

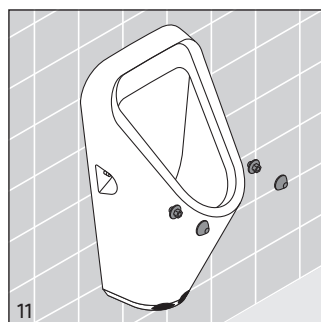

Attach nuts and chrome plated caps.

装上螺帽和镀铬罩。

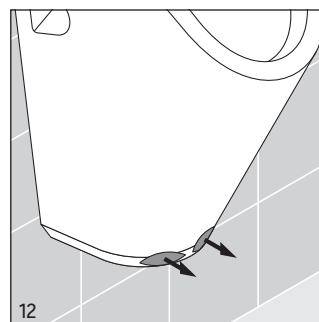

Remove sensor film.

取掉感应遮光胶片。

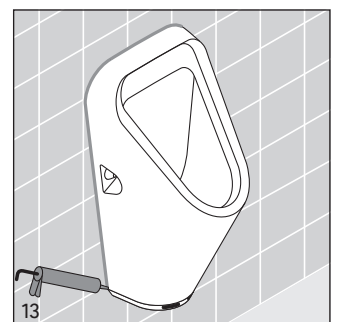

Add silicon around the base.

沿墙与坐便器底部接缝处涂上一层硅胶。

Battery replacement

更换电池

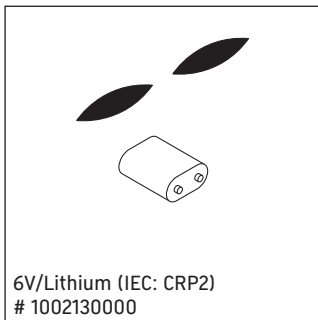

6V/lithium battery and sensor films.

6V/锂电池和感应遮光胶片。

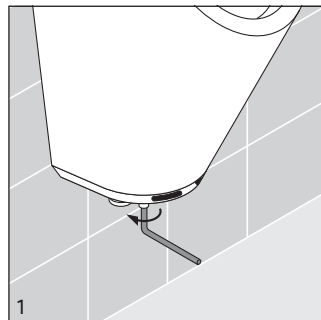

Using Allen wrench (4 mm) unscrew the bottom portion of the electronic unit.

用内六角扳手（4毫米）将电子元件的底部拧松。

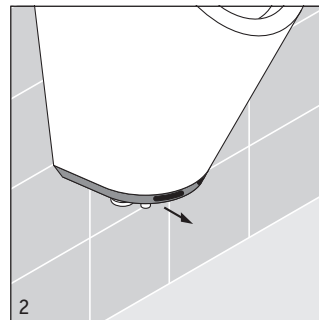

Slide the electronic unit forward.

将金属罩向胸前滑动。

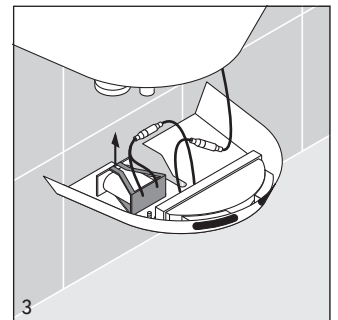

Detach and remove old 6V lithium battery.

拆下旧的6V锂电池。

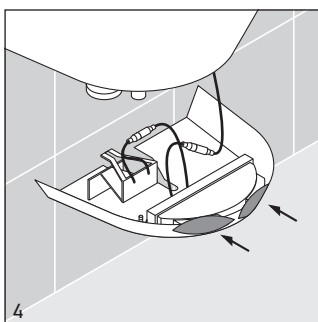

Place film onto the sensors.

一定要先将遮光胶片盖住感应窗。

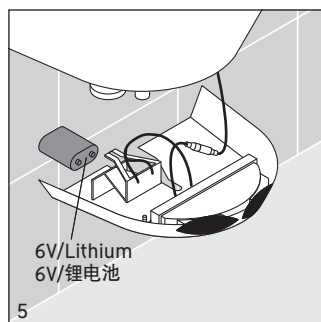

Install new 6V lithium battery.

安装新的6V锂电池。

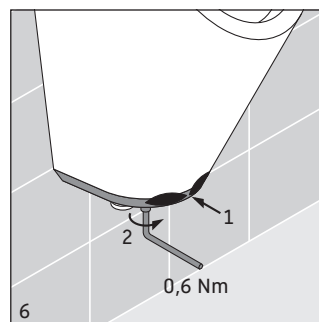

Using Allen wrench (4 mm) tighten the electronic unit.

用内六角扳手（4毫米）将金属罩拧紧。

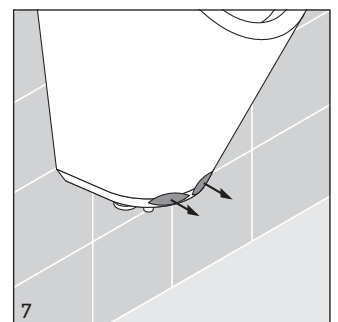

Remove film from the sensor and refer to page 8 for starting instructions.

取掉感应遮光胶片，启动说明请参见第八页。



Replacing the solenoid valve

更换电磁阀

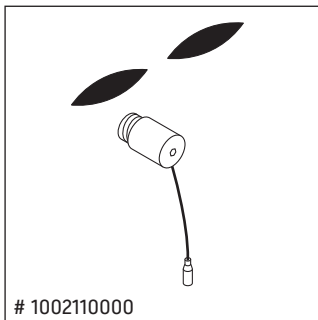

Solenoid valve and sensor films.

电磁阀和遮光胶片。

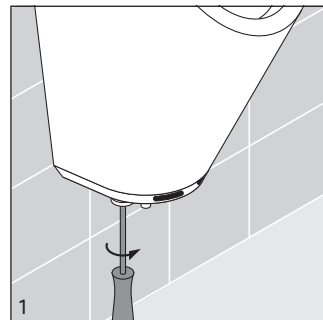

1 Using the screwdriver and close the stop valve (7 turns).

用螺丝刀关闭截止阀（7圈）。

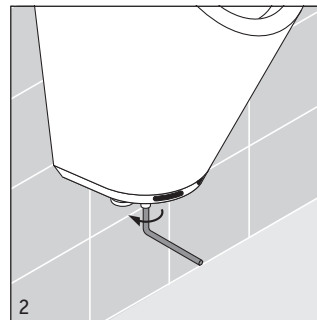

2 Using Allen wrench (4 mm) unscrew the bottom portion of the electronic unit.

用内六角扳手（4毫米）将金属罩的底部拧松。

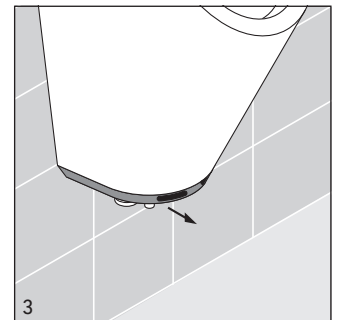

3 Slide the electronic unit forward.

将金属罩向胸前滑动。

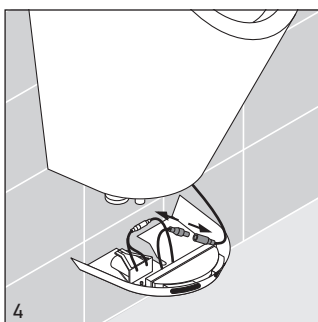

4 Detach electrical connection and remove the electronic unit.

拆开连接插件,卸下金属罩。

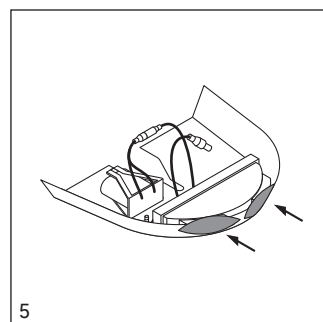

5 Place the sensor film on the electronic unit.

一定要先将遮光胶片盖住感应窗。

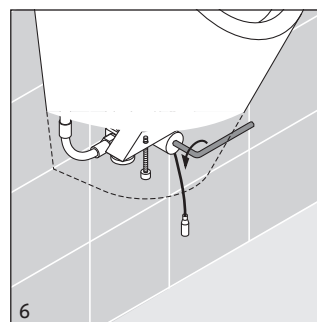

6 Using the Allen wrench (6 mm) unscrew the solenoid valve.

用内六角扳手（6毫米）将电磁阀拧松。

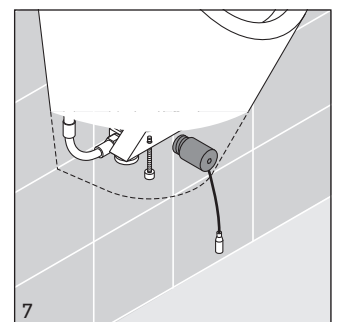

7 Remove the solenoid valve.

取下电磁阀

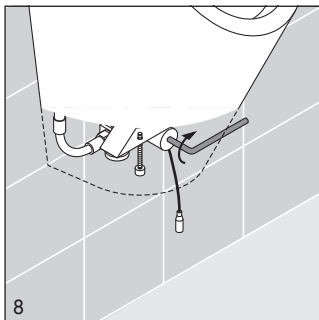

8
Replace the solenoid valve turning the Allen wrench clockwise (4³/₄ turns).

更换电磁阀，顺时针方向转动内六角扳手（4-3/4圈）。

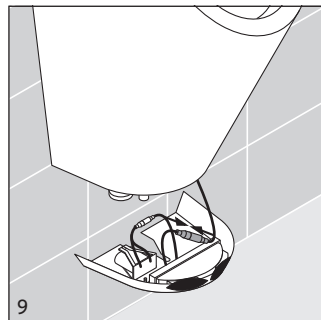

9
Attach electrical connection.

连接连接插件。

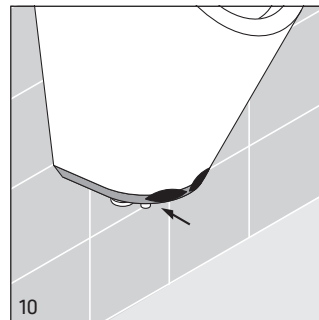

10
Push the electronic unit forward.

将金属罩向胸前滑动。

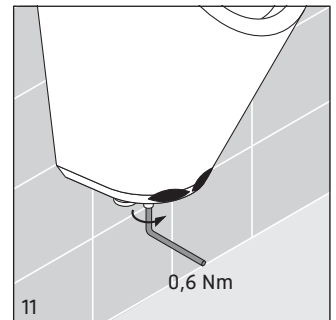

11
Using Allen wrench (4 mm) tighten the electronic unit.

用内六角扳手（4毫米）将金属罩拧紧。

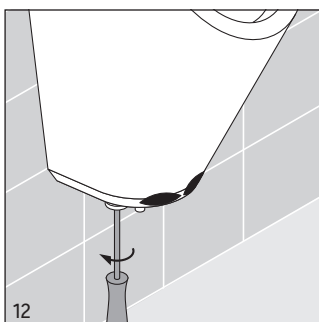

12
Using the screwdriver and open the stop valve (7 turns).

用螺丝刀将截止阀打开（7圈）。

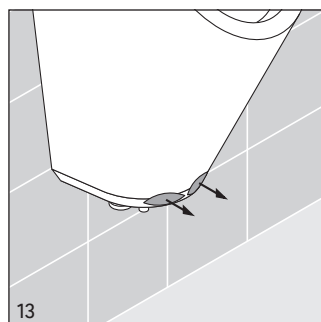

13
Remove the sensor film and refer to page 8 for starting instructions.

取下感应遮光胶片，启动说明请参见第八页。

Replacing the electronic unit

更换电子元件

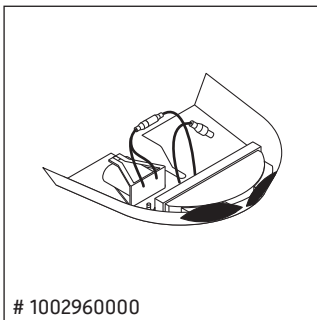

1002960000

Electronic Unit

电子元件

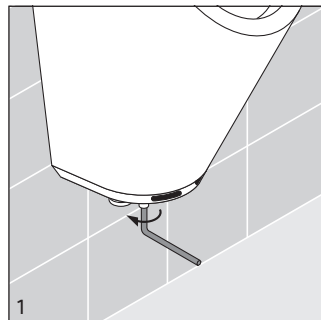

1 Using Allen wrench (4 mm) unscrew the bottom portion of the electronic unit.

用内六角扳手（4毫米）将金属罩的底部拧松。

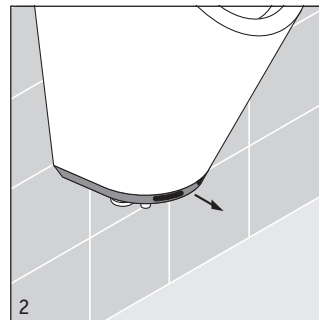

2 Slide the old electronic unit forward.

将金属罩向胸前滑动。

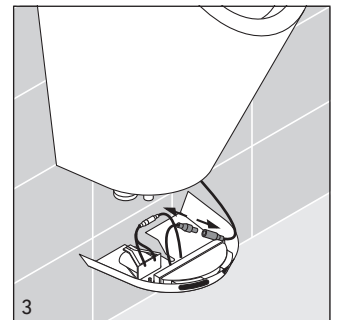

3 Detach electrical connection.

拆开连接线插件。

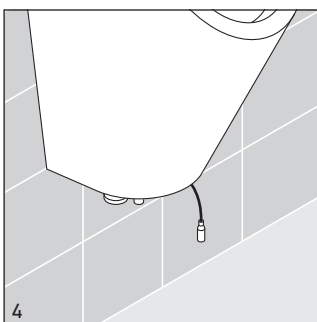

4 Remove the electronic unit.

卸掉电子元件。

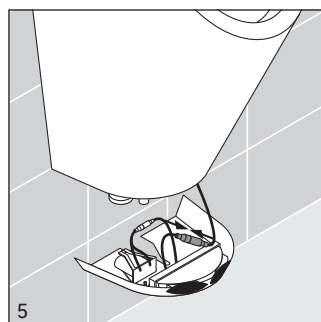

5 Attach electrical connection (new electronic unit).

接上连接线插件。（新的电子元件）

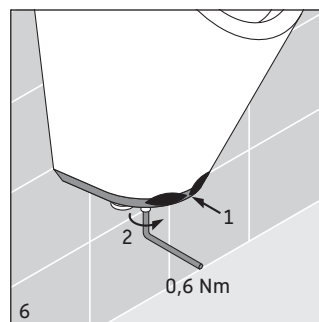

6 Using Allen wrench (4 mm) tighten the electronic unit.

用内六角扳手（4毫米）将金属罩拧紧。

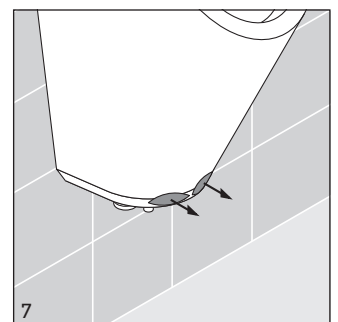

7 Remove film from the sensor and refer to page 8 for starting instructions.

取下感应遮光胶片，启动说明请参见第八页。



Cleaning the dirt trap

清理存水弯

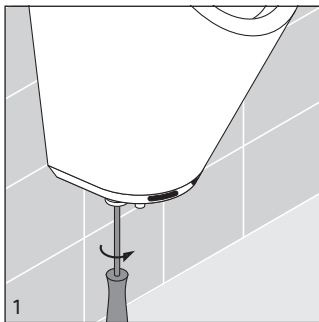

Using the screwdriver and close the stop valve (7 turns).

用螺丝刀关闭截止阀（7圈）。

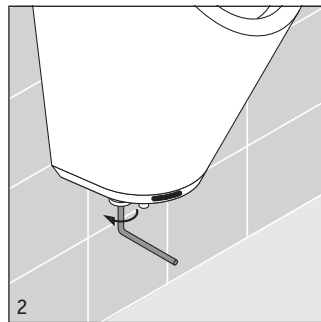

Using the Allen wrench (10 mm) unscrew the cap of the stop valve.

用内六角扳手（10毫米）拧松截止阀的盖帽。

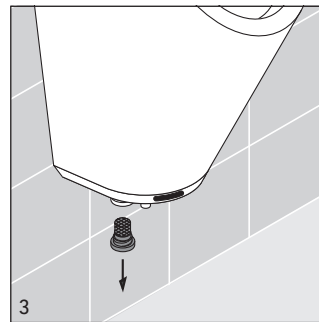

Remove and clean the dirt trap.

卸下并清理存水弯

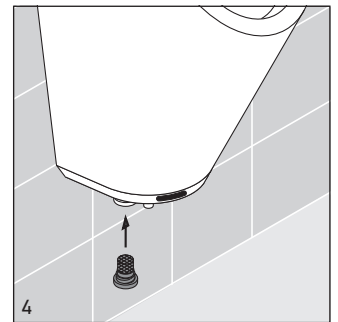

Install cleaned dirt trap.

装上清理好的存水弯

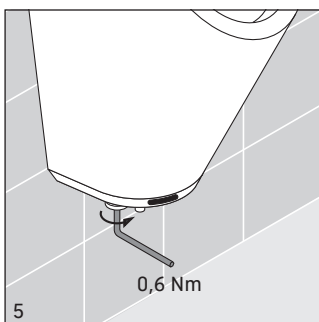

Using Allen wrench (10 mm) tighten the cap of the stop valve.

用内六角扳手（10毫米）拧紧截止阀的盖帽。

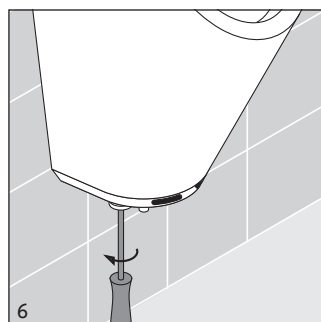

Using the screwdriver and open the stop valve (7 turns).

用螺丝刀打开截止阀（7圈）。

Removing errors

ERROR	▷ SOURCE OF ERROR	▶ REMOVE ERROR	SEE PAGE	ARTICLE-CODE
No flush but click of magnetic valve	▷ Closed stop valve	▶ Open stop valve	-	-
	▷ Blocked dirt trap	▶ Clean dirt trap	13	-
	▷ Battery empty	▶ Replace battery	9	1002130000
	▷ Broken magnetic valve	▶ Replace magnetic valve	10 - 11	1002110000
No flush, no click of magnetic valve	▷ Empty battery	▶ Replace battery	9	1002130000
	▷ Electrical interruption	▶ Check electrical connections	-	-
	▷ Electronic unit out of order	▶ Replace electronic unit	12	1002960000
Flush without use	▷ Broken magnetic valve	▶ Replace magnetic valve	10 - 11	1002110000
	▷ Wrong sensor focus	▶ Restart electronic unit*	see explanation* below	
Permanent flush	▷ Broken electronic unit	▶ Replace electronic unit	12	1002960000
	▷ polluted magnetic valve	▶ Clean membrane of magnetic valve or replace magnetic valve	10 - 11	1002110000
	▷ Broken magnetic valve	▶ Replace magnetic valve	10 - 11	1002110000

*RESTART ELECTRONIC UNIT

Cover sensor with black tape
 Unscrew metal cover
 Unplug battery
 Plug battery
 Screw on metal cover
 Remove black tape from sensor

可能发生的故障及解决办法

可能发生的故障	故障原因	解决办法	参考页数	产品编号
小便器不冲水而电磁阀有声音	▷ 截止阀关闭	▶ 打开截止阀	-	-
	▷ 存水弯堵塞	▶ 清理存水弯	13	-
	▷ 电池电量不足	▶ 更换电池	9	1002130000
	▷ 电磁阀损坏	▶ 更换电磁阀	10 - 11	1002110000
小便器不冲水，电磁阀没有声音	▷ 电池电量不足	▶ 更换电池	9	1002130000
	▷ 电子干扰	▶ 检查电子元件	-	-
	▷ 电子元件发生故障	▶ 更换电子元件	12	1002960000
	▷ 电磁阀损坏	▶ 更换电磁阀	10 - 11	1002110000
非使用时冲水	▷ 感应源错误	▶ 重新启动电子元件	请见下面带*注释	
	▷ 电子元件发生故障	▶ 更换电子元件	12	1002960000
持续冲水	▷ 电磁阀受到污染	▶ 清理电磁阀膜片或 更换电磁阀	10 - 11	1002110000
	▷ 电磁阀损坏	▶ 更换电磁阀	10 - 11	1002110000

* 重新启动电子元件
 用遮光胶片盖住感应窗口
 松开金属罩
 取出电池
 装上电池
 拧紧金属罩
 取掉遮光胶片



Duravit AG
Werderstr. 36
78132 Hornberg
Germany
Phone +49 78 33 70 0
Fax +49 78 33 70 289
info@duravit.de
www.duravit.de

